

KOMATSU

BR380JG-1

ENGINE POWER
149 kW / 200 HP @ 2.050 rpm

OPERATING WEIGHT
32.600 - 34.000 kg

TREATMENT CAPACITY
50 - 240 ton/h

BR
380



MOBILE CRUSHER

BR380JG-1

WALK-AROUND

The newly designed Komatsu BR380JG-1 mobile crusher looks simple, and it's very powerful. This newly developed crusher offers you an amazing crushing capacity of **50 - 240 ton/h.**

High-performance jaw

The KCJ4222 large-capacity jaw crusher guarantees the greatest treatment capacity in its class, plus easy maintenance. In addition, Komatsu's original bear lock cylinder mechanism allows you to change the discharge clearance with a simple one-touch adjustment, and it also facilitates the removal of clogged foreign material from the discharge side.

Newly designed vibratory grizzly feeder

The vibrator grizzly feeder pushes the material up elliptically, so that the material can be effectively separated and evenly fed into the jaw.

HydraMind hydraulics and all-hydraulic drive system

A full hydraulic drive system starts your work right away. The HydraMind system supplies an optimal amount of oil through the load-sensing and pressure-compensated valves. Optional equipment can be connected to the hydraulic outlets on the chassis (option).

Large-capacity hopper

The 2.500 mm × 3.700 mm hopper is accessible for material loading from three sides.



Komatsu Tracking System

Track and monitor your machine anytime, anywhere for total peace of mind.

Hydraulic conveyor lifter

In the upper position, it ensures adequate ground clearance when driving, plus safe driving – even on rough ground.



ENGINE POWER

149 kW / 200 HP @ 2.050 rpm

OPERATING WEIGHT

32.600 - 34.000 kg

TREATMENT CAPACITY

50 - 240 ton/h

Rotary lamp

Lights up whenever the crusher is overloaded or in trouble.

**High-speed, large-capacity conveyor belt**

The 1.050 mm (1.000 mm) wide conveyor belt travels at 120 m per minute. The discharge height is 2.800 mm.

**Komatsu's SAA6D107E-1**

engine with high pressure common rail injection provides 149 kW (200 HP) @ 2.050 rpm for superior crushing power. The engine meets EU Stage IIIA and EPA Tier III emissions regulations.

Emergency shut-off buttons

are installed on both the left and right sides of the chassis, on the control panel, and on the (optional) radio remote control.

Outstanding mobility

Hydraulic steering and high-travel speed makes it easy to relocate the machine. The BR380JG-1 uses the same track undercarriage as those used on Komatsu's hydraulic excavators.

PRODUCTIVITY FEATURES

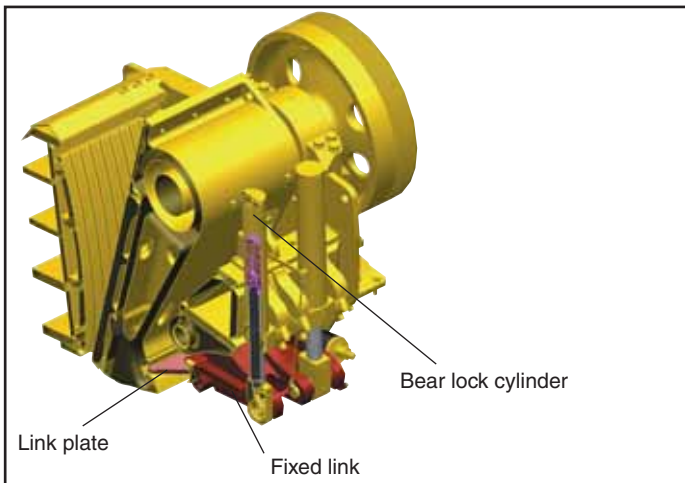

Equipped with the largest jaw crusher in its class, the BR380JG-1 offers the performance of larger crusher units.

The largest jaw crusher in its class

The large-capacity KCJ4222 jaw crusher is another successful example of Komatsu's development efforts. Crushing efficiency is substantial, thanks to the installation of a load-presetting semi-automatic feeder system and rapid crusher rotation speed.



Feed opening:
1.065 mm x 550 mm

KCJ4222 Jaw

Fully automatic discharge clearance adjustment system

The jaw crusher is equipped with an automatic discharge clearance adjustment system that makes it easy to change the preset aperture of the discharge port. Even when both of the jaw plates are worn out, you can adjust the discharge clearance with a simple one-touch operation (this adjustment is completed within one minute). On the monitor panel, you can choose one of the three adjustment modes (patent pending).

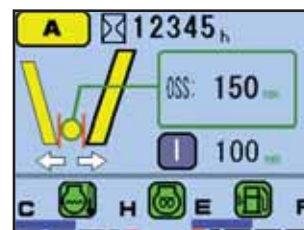

Fully automatic discharge clearance adjustment system

- Mode A:** Input a desired value for the discharge clearance.
- Mode B:** Increase or decrease the current discharge clearance.
- Mode C:** Push down the manual switch to increase or decrease the present discharge clearance.

A unique hydraulic crusher protection mechanism

Most jaw crushers only protect themselves with bending toggle plates when they are clogged or jammed with metal debris. The KCJ4222 protects itself by allowing the bear lock cylinders to fully open the discharge port, which makes it easy to remove clogged foreign material from the crusher (Patent pending).



Hydraulic crusher protection mechanism

Large treatment capacity

Komatsu's original large-capacity jaw crusher and the most advanced control systems deliver a substantial throughput capacity, making it easy to manage large workloads.

Treatment capacity (ton/h)

Maximum treatment capacity (with a muck content of 30%)

Material	Crusher discharge setting (open side)			
	50 mm	80 mm	120 mm	150 mm
Natural stone	50 - 70	80 - 115	125 - 180	170- 240
Concrete debris	60 - 85	90 - 130	125 - 175	150 - 215

Note:
The treatment capacity is the sum of the volume of the material crushed by the crusher and the volume of the material that passes through the grizzly bar. This depends on the type and properties of the material and the working conditions.

High-speed, large-capacity conveyor belt

The high discharge height of 2.800 mm makes it easy to configure a system with product stockpilers and screens. With its width of 1.050 mm and a travel speed of 120 m/min., the conveyor belt has a large transportation volume capacity. In addition, the conveyor reverse mode is provided to facilitate the removal of jammed foreign matter.



Substantial mobility

The conveyor elevation system has a substantial ground clearance, which assists the crusher's outstanding manoeuvrability at all crushing sites.

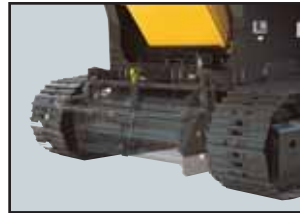

Minimum ground clearance –
When traveling:
300 mm
When crushing:
100/200 mm

Conveyor elevation system

Easy maintenance and safety

Maximum reliability and minimal maintenance

In addition to the spacious gap of 530 mm between the jaw crusher and the conveyor belt, the crusher's outlet area is protected by covers. This design prevents reinforced bars from being caught by the crusher's member structure. Wide openings on the side frames also ensure easy access to the space below the crusher to remove clogged foreign material.



Opening under the engine side



Opening under the crusher side (both sides of the undercarriage)

Environmentally friendly design

BR380JG-1 is in conformance with EU Stage IIIA and EPA Tier III emissions regulations. Despite the high power of 149 kW (200 HP), the mobile crusher emits a very low noise.

To prevent dust generation, sprinkler nozzles are provided as a standard attachment at the top of the jaw crusher. The sprinkler system (with water tank and pump) is optional.



Low-noise engine



Sprinkler nozzle

Easy operation

All operation switches are consolidated onto a control panel, making it easier for the operator to reach it and safely control operations whilst standing on the ground. The crusher operation mode can be changed from crushing into travel mode with the radio control unit (option), making it easy for the operator to control all functions from distance. Because the control system is equipped with a one-touch start feature, a single push of the start switch commences operations. The multi-function monitor displays the status of all the components in real time.



Main control panel

Safety

Emergency shut-off buttons are located on the left and right sides of the chassis, on the control panel, and in the (optional) radio remote controller.

A rotating lamp flashes when there is a malfunction on the monitor display (for example, when overheating occurs) and the operator is also alerted by a buzzer in the event of an abnormal shut-down on the conveyor belt or optional equipment.

A switch is provided to change between crushing and travel modes. Handrails and safety guards are provided for all sections.



Traveling mode



Crushing mode

SPECIFICATIONS



ENGINE

Model..... Komatsu SAA6D107E-1
 Type..... Common rail direct injection, water-cooled, emissionised, turbocharged, after-cooled diesel
 Engine power
 at rated engine speed2.050 rpm
 ISO 14396..... 149 kW / 200 HP
 SAE J1349 (net engine power) 140 kW / 188 HP
 No. of cylinders 6
 Bore x stroke 107 x 124 mm
 Displacement..... 6,69 ltr
 Governor..... All-speed, electrical



HYDRAULIC SYSTEM

Type..... HydraulMind. Closed-centre system with load sensing and pressure compensation valves
 Main pump..... 2 variable displacement piston pumps
 Pumps for Travel, crusher, feeder, conveyor and 4 equipment options
 Maximum pump flow..... 2 x 230 ltr/min
 Maximum pressure 380 kg/cm²
 Maximum travel speed..... 3 km/h
 System oil flow (travel, crusher, feeder, conveyor, and option)
 Travel 2 x 160 ltr/min
 Crusher 230 ltr/min
 Feeder..... 58 ltr/min
 Conveyor..... 38 ltr/min
 Options..... 28 ltr/min



TRANSPORTATION

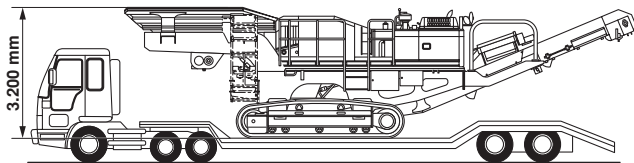

Transport length	12.500 mm
Transport height	3.200 mm
Transport width	2.800 mm

(In some countries, the machine may need to be disassembled for transportation)



OPERATING WEIGHT (APPR.)

Operation weight, including 500 mm shoes..... 32.600 kg
 Operation weight, including 500 mm shoes, muck conveyor and magnet..... 34.000 kg



CRUSHER

Jaw Komatsu KCJ4222
 Inlet size 1.065 mm x 550 mm
 Discharge setting (O.S.S)..... 50 - 150 mm
 Production capacity (indication)..... 50 - 240 ton/h
 Rotating speed (variable) 170 - 330 rpm



GRIZZLY FEEDER

Frequency (max.) 1.100 rpm
 Size..... 1.000 mm x 3.220 mm
 Amplitude (not loaded, all amplitude) 10 mm
 Drive type Direct drive with hydraulic motor



UNDERCARRIAGE

Track assembly
 Type..... Fully sealed
 Shoes (each side) 45
 Shoe width..... 500 mm
 Rollers
 Track rollers (each side) 5
 Carrier rollers (each side) 2



COOLANT AND LUBRICANT CAPACITY (REFILLING)

Fuel tank..... 400 ltr
 Radiator 20,6 ltr
 Engine oil 23,1 ltr
 Final drive (each side) 4,5 ltr
 Hydraulic tank..... 112 ltr



ENVIRONMENT

Engine emissions Fully complies with EU Stage IIIA and EPA Tier III exhaust emission regulations

Noise levels

Ambient noise (at radius of 7 m) from engine, high engine speed, crusher on without load..... < 80 dB(A)

DIMENSIONS

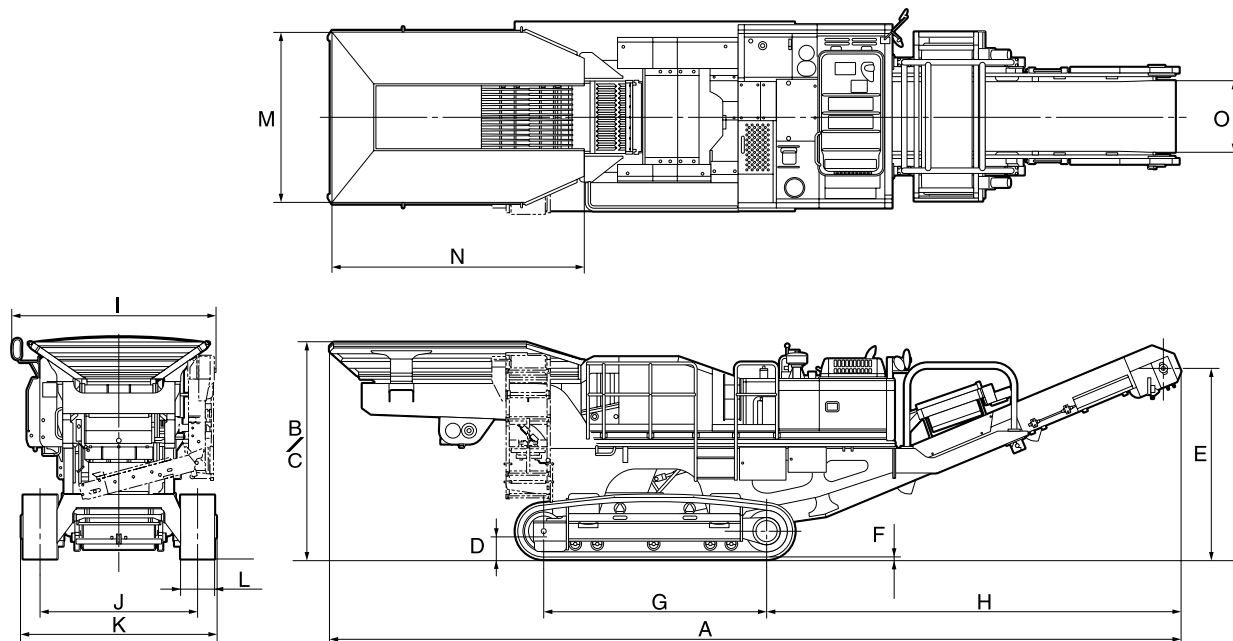

MACHINE DIMENSIONS		BR380JG-1
A	Overall length	12.500 mm
B	Overall height	3.200 mm
C	Feeder height (side)	3.200 mm
D	Minimum ground clearance (traveling)	300 mm
E	Discharge height	2.800 mm
F	Grouser height	26 mm
G	Length of track on ground	3.275 mm
H	Discharge from idler center	6.080 mm
I	Overall width	2.950 mm
J	Track gauge	2.280 mm
K	Track width	2.815 mm
L	Shoe width	500 mm
M	Hopper width	2.500 mm
N	Hopper length	3.700 mm
O	Discharge conveyor belt width	1.050 mm

MOBILE CRUSHER



STANDARD EQUIPMENT

Engine:

- Komatsu SAA6D107E-1, 149 kW turbocharged common rail direct injection diesel engine, EU Stage IIIA compliant
- Suction type cooling fan
- Air cleaner, centrifugal method with paper filter and pre-filter

Electrical system:

- Starting motor 5,5 kW/24 V
- Alternator 35 A/24 V
- Battery 2 × 12 V/110 Ah

Undercarriage:

- 500 mm assembled triple-grouser type

Crusher:

- KCJ4222 single-toggle crusher
- Size: 1.065 mm × 550 mm
- Rotation: 170 - 330 rpm
- Drive method: hydraulic motor with V-belt
- Setting OSS: 50 - 150 mm

Feeder:

- Type: 2-step deck
- Speed-controlled grizzly feeder
- Dimensions (W × L): 1.000 mm × 3.220 mm
- Grizzly bar opening: 25 - 50 mm
- Drive method: hydraulic gear motor

Belt conveyor:

- Width × length: 1.050 mm × 9.550 mm
- Speed: 120 m/min
- Drive method: hydraulic piston motor

Muck conveyor:

- Muck conveyor assembly can be folded by hydraulic cylinder: 3.000 mm × 500 mm

Control systems

- Komtrax™ Komatsu tracking system

OPTIONAL EQUIPMENT

Magnetic separator:

- Magnetic separator for primary conveyor (900 mm)
- Hydraulic driven by gear pump

Water tank & spraying system:

- Hoses
- Pump
- Tank

Radio remote controller (functions):

- Change between travel and crushing mode
- Travel Left/Right/Forward/Reverse
- Crusher On/Off
- Feeder On/Off

- Emergency shut off
- Horn

KOMATSU

Komatsu Europe International NV

Mechelsesteenweg 586
B-1800 VILVOORDE (BELGIUM)
Tel. +32-2-255 24 11
Fax +32-2-252 19 81
www.komatsueurope.com