

KOMATSU®

BR550JG-1

FLYWHEEL HORSEPOWER
228 kW 306 HP @ 1950 rpm

OPERATING WEIGHT
47500 kg 104,720 lb



BR
550
JG



MOBILE CRUSHER

BR550JG-1 Mobile Crusher

WALK-AROUND

Komatsu's newly designed BR550JG-1 enters the market as the most technologically advanced machine available. With excellent crushing power and a treatment capacity of **100–460 ton/h** 110–507 U.S. ton/h, the Komatsu BR550JG-1 is the optimum choice for your work site.

Rotating lamp flashes to indicate travel mode, excessive load on crusher or abnormal condition.

High performance jaw. The FS4430QA maximum-capacity jaw provides high performance with a simple design that facilitates easy maintenance. Komatsu's unique design allows the discharge setting to be changed with a simple one-touch adjustment in less time than the competition.

Newly designed vibratory grizzly feeder. The vibratory grizzly feeder vibrates the material with an elliptical movement, so that the materials are effectively separated and fed evenly into the jaw.

HydraMind hydraulics and all-hydraulic drive system. Fully hydraulic drive system gets you working right away. HydraMind system supplies the optimal amount of oil through load-sensing and pressure-compensated valves. Optional equipment can be connected through hydraulic outlets in the chassis.

Outstanding mobility. Hydraulic steering and high travel speed make the crusher easy to relocate. The BR550JG-1 uses the same track undercarriage as Komatsu Hydraulic Excavators.



BR550JG-1

MOBILE CRUSHER

FLYWHEEL HORSEPOWER
228 kW 306 HP @ 1950 rpm

OPERATING WEIGHT
47500 kg 104,720 lb

TREATMENT CAPACITY
100–460 ton/h
110–507 U.S. ton/h

Foldable hopper for easy loading and transport. The overall height of the hopper (which can be loaded from three sides) is only **3365 mm 11'0"** high (rear side).



High-speed, large-capacity conveyor belt. A **1050 mm 3'5"** (**1000 mm 3'4"**) wide belt moves at **120 m 393'8"** per minute. The discharge height is **3000 mm 9'10"**.

Komatsu's SAA6D125E-2 engine provides **228 kW 306 HP @ 1950 rpm** for maximum crushing power while keeping exhaust gas, noise, and vibration to a minimum.

Hydraulic conveyor lifter at the high position ensures adequate ground clearance when driving, and safe driving even when on uneven ground.

Sprinkler nozzle and a **connector** are standard.

Emergency shut-off buttons are installed on both the left and right sides of the chassis, control panel, and radio remote control (optional).

PRODUCTIVITY FEATURES

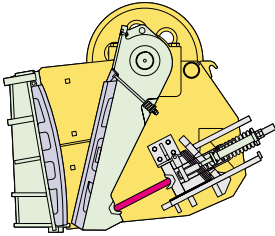

Designed with the operator in mind, the crusher offers the most up-to-date technological advancement to assist with your crushing needs.

Equipped with FS4430QA Jaw Crusher

The powerful FS4430QA jaw crusher with bow-type fixed jaw at high rpm allows you to adjust setting ranges from **55 mm to 200 mm** 2.2"–7.9" (OSS) for maximum crushing capabilities, including concrete debris and hard rock. Komatsu's one-touch setting adjustment also allows greater control over your crushing capacity.

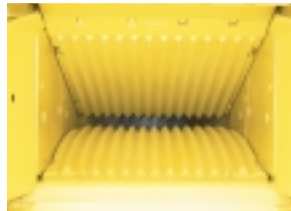

FS4430QA Jaw



GAP Adjust Cylinder



Adjustment Switch

- **Maximum crushing efficiency.** The Komatsu semi-automatic feeder system senses the load on the crusher and adjusts the feed rate accordingly to maximize efficiency for all types of rock and concrete debris.
- **Hopper for easy loading.** The loading height of the hopper is only **3365 mm** 11'0" (rear side).
- **Newly designed vibrating grizzly feeder.** By raising the feeder angle to an incline of 4° the muck is more effectively removed and the elliptical movement of the 2-stage grizzly feeder reduces clogging. Also, an optional muck conveyor is available to separate the materials.
- **High-speed, large-capacity conveyor belt.** A **1050 mm** 3'5" (**1000 mm** 3'4") wide belt moves quickly to discharge crushed materials. Discharge height is **3 m** 9'10", which facilitates stocking and screening the products.
- **High-volume capacity.** By utilizing the latest in technology in the development of the large-sized, high-speed crusher, the Mobile Crusher maximizes the volume of materials that can be crushed and passed through the grizzly feeder.



Load-setting Control Dial



Cassette-type Grizzly Bar



Treatment Capacity

Maximum treatment capacity (with a muck content of 30%).

Unit: **ton/h** U.S. ton/h

Material	Crusher Discharge Setting (open side)				
	55 mm 2.2"	70 mm 2.8"	100 mm 3.9"	150 mm 5.9"	200 mm 7.9"
Natural stone	—	—	130–180 143–198	200–280 220–309	280–400 309–441
Concrete debris	100–140 110–154	110–160 121–176	150–220 165–243	230–330 254–364	320–460 353–507

*The treatment capacity of the natural stones shown in the table is based on andesite having unconfined compression strength of about **1000 kg/cm²**, that of the concrete debris is based on concrete debris containing no steel bars and all the material is assumed to be dry and equal to or smaller than the optimum feed-in material size.

The treatment capacity is the sum of the quantity of the material crushed by the crusher and the quantity of the material that passed through the grizzly bar. It depends on the type and properties of the material and the working condition.

When the crusher discharge setting is **55–100 mm** 2.2"–3.9", only concrete debris can be crushed.

- **High mobility.** The overall height for transportation is reduced below **3.4 m 11'2"** by employing the hydraulic cylinder to fold the hopper. The BR550JG-1 has high ground clearance. The hydraulic conveyor elevator function ensures ample ground clearance when relocating the machine. The optional radio controller allows remote control travel functions.



Folding Hopper



Lifting Function of Conveyor

EASY MAINTENANCE AND SAFETY

Maximum Reliability and Minimal Maintenance. Komatsu equipment offers exceptional reliability and the leading edge in technological advancement. The new trouble monitoring system improves maintenance, while standard features such as the pre-cleaner and double cleaner element are installed to increase operator comfort and improve dust resistance. A large ground clearance under the crusher means easier maintenance. Even if trouble occurs it can be repaired in a short time.

Comfortable Design. In addition to a low-noise engine made with sound-absorbing materials, Komatsu installs low-speed and high-torque hydraulic pumps, a muffler, and other standard parts to reduce noise and vibration. In addition, every crusher is equipped with a standard water sprinkler nozzle to suppress dust and improve the environment.

Easy Operation. The Mobile Crusher offers high-performance functions. The crusher setting can be completed in 3 minutes with the easy setting adjustment mechanism. The crusher, feeder, discharge conveyor belt, and optional equipment can all be operated at the touch of a button. With the optional remote control, operator control is maximized.

Safety

- Emergency shut-off buttons are located on the left and right sides of the chassis, on the control panel, and the remote control (optional).
- A rotating lamp flashes when there is a malfunction on the monitor display (for example, when overheating occurs) and the operator is also alerted by a buzzer in the event of an abnormal shut-down on the conveyor belt or optional equipment.
- A switch is provided to change between crushing and travel modes.
- Handrails and safety guards are provided for all sections.



Openings on Crusher Side



Low-Noise Engine



Water Sprinkler Nozzle

Upper Control Panel

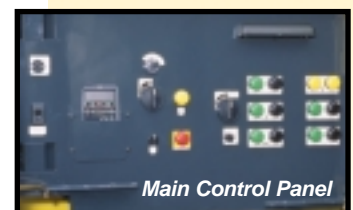
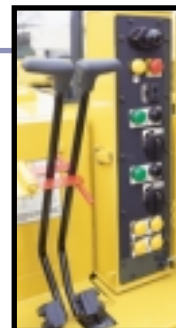

Main Control Panel



SPECIFICATIONS



ENGINE

Model Komatsu SAA6D125E-2
 Type 4-cycle, water-cooled, direct injection
 Aspiration Turbocharged and aftercooled (air to air)
 Number of cylinders 6
 Bore **125 mm** 4.92"
 Stroke **150 mm** 5.91"
 Piston displacement **11.04 ltr** 674 in³
 Flywheel horsepower **228 kW** 306 HP @ 1950 rpm (SAE J1349)
 Governor All-speed, electrical



HYDRAULIC SYSTEM

Type Variable capacity with pistons (inclined plate type)
 Main pump:
 Type Variable-capacity pistons
 Pumps for Travel, crusher, conveyor, and options
 Maximum flow **2 x 310 ltr/min** 2 x 82 U.S. gpm
 Maximum pressure **380 kg/cm²**
 Maximum travel speed **3 km/h** 1.9 mph
 Hydraulic system (travel, crusher, feeder, conveyor, and option):
 Travel **220 ltr/min** 58 U.S. gpm
 Crusher **325 ltr/min** 86 U.S. gpm
 Feeder **110 ltr/min** 29 U.S. gpm
 Main conveyor **90 ltr/min** 24 U.S. gpm
 Muck conveyor **47 ltr/min** 12 U.S. gpm
 Magnetic separator **36 ltr/min** 10 U.S. gpm



TRANSPORTATION

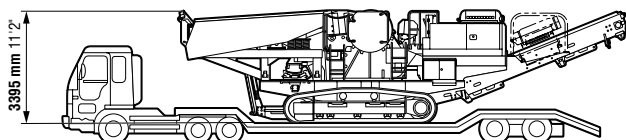

Condition after rotary lamp assembly, muffler, pre-cleaner, and mirror assembly are removed.

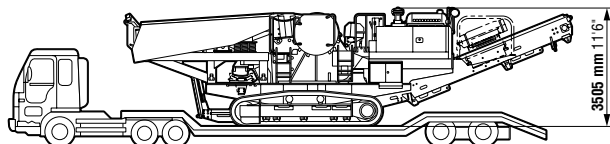

Condition after only rotary lamp and muffler are removed.
 (In some districts, the machine may need to be disassembled for transportation.)

Transport length	13430 mm	44'1"
Transport height	3395 mm	11'2"
Transport height*	3505 mm	11'6"
Transport width	2995 mm	9'10"

*Condition after only rotary lamp and muffler are removed.



OPERATING WEIGHT

Operating weight, including 500 mm shoes **47500 kg** 104,720 lb
 Treatment capacity **100–460 ton/h** 110–507 U.S. ton/h



CRUSHER

Jaw Komatsu FS4430QA
 Inlet size **1120 mm x 765 mm** 44" x 30"
 Discharge setting (O.S.S.) **55 mm to 200 mm** 2.2" to 7.9"
 Rotating speed (variable) 210–300 rpm



GRIZZLY FEEDER

Frequency Maximum 1000 cpm
 Size **1125 mm x 4105 mm** 44" x 13'6"
 Drive type Hydraulic gear motor



UNDERCARRIAGE

Seal of track Sealed track
 Track adjuster Hydraulic
 Number of shoes 45 each side
 Number of carrier rollers 2 sets/one side
 Number of track rollers 5 sets/one side



COOLANT AND LUBRICANT CAPACITY

Fuel tank **605 ltr** 160 U.S. gal
 Radiator **43.9 ltr** 12 U.S. gal
 Engine **38 ltr** 10 U.S. gal
 Final drive, each side **9 ltr** 2.4 U.S. gal
 Hydraulic system **370 ltr** 98 U.S. gal



DIMENSIONS

When Operated

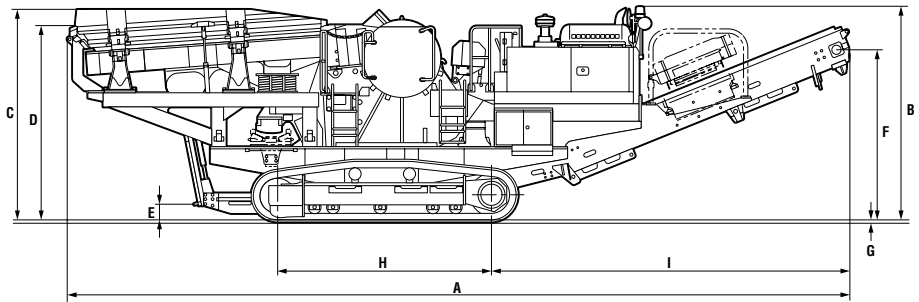
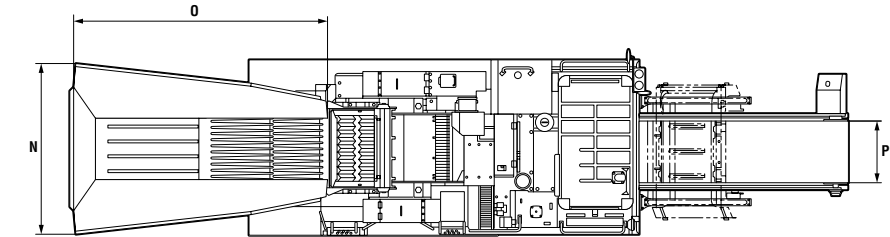
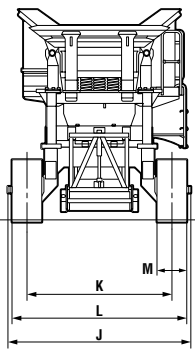

When Hopper Is Folded

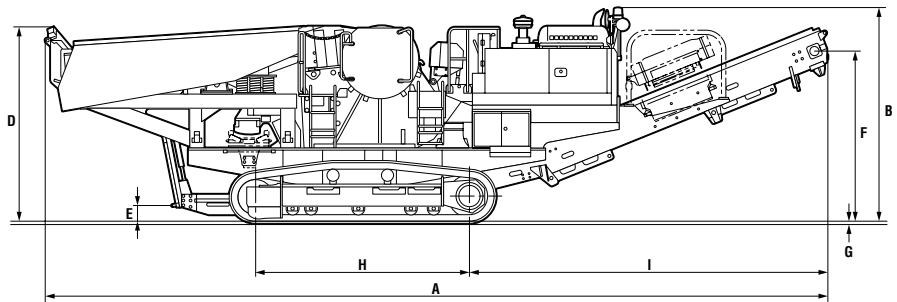
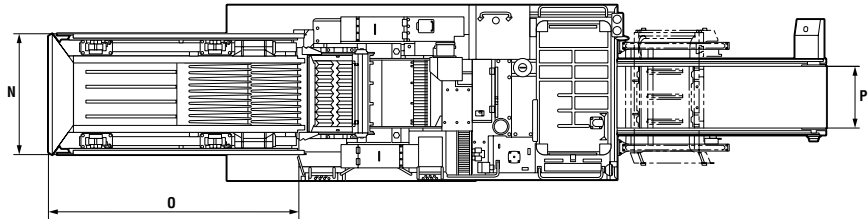
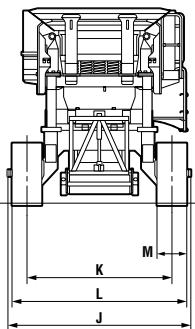

A	Overall length	13430 mm	44'1"
B	Overall height	3640 mm	11'11"
C	Feed height—side	3640 mm	11'11"
D	Feed height—rear	3365 mm	11'0"
E	Minimum ground clearance (during travel)	350 mm	1'2"
F	Discharge height	3000 mm	9'10"
G	Track thickness	30 mm	1"
H	Length of track on ground	3700 mm	12'2"
I	Discharge from idler center	6145 mm	20'2"

J	Overall width	3115 mm	10'3"
K	Track gauge	2480 mm	8'2"
L	Track width	2980 mm	9'9"
M	Shoe width	500 mm	19.7"
N	Hopper width	2805 mm	9'2"
	Hopper width when folded	2130 mm	7'0"
O	Hopper length	4365 mm	14'4"
P	Discharge conveyor belt width	1050 mm	3'5"
Note: 1000 mm 3'4" is available			



STANDARD EQUIPMENT

ENGINE:

- Engine, Komatsu SAA6D125E-2
- 4-cycle, water-cooled, direct injection, turbocharged, and aftercooled (air to air)
- Net horsepower **228 kW** 306 HP @ 1950 rpm
- Fuel system:
 - Fuel, light oil, ASTM specification
 - Governor, centrifugal method, all-speed method
- Cooling fan, suction type
- Air cleaner, centrifugal method with paper filter

ELECTRICAL SYSTEM:

- Starting motor, **11 kW** 24 V
- Alternator, **50 ampere** 24 V
- Battery, **140 Ah** 2 x 12 V

UNDERCARRIAGE:

- Number of rollers:
 - Upper carrier, two sets/one side
 - Lower track, five sets/one side

SHOES:

- Assembled triple-grouser type, **500 mm** 19.7"
- Tension adjustment, grease cylinder method (cushion springs attached)

CRUSHER:

- Type, FS4430QA single-toggle crusher
- Size, **1120 mm x 765 mm** 44" x 30"
- Rotation, 210–300 rpm
- Drive method, hydraulic motor with V-belt

FEEDER:

- Type, 2-step deck
- Speed controlled grizzly feeder
- Dimensions (W x L), **1125 mm x 4105 mm** 44" x 13'6"
- Grizzly bar opening, **45–70 mm** 1.77"–2.76"
- Drive method, hydraulic gear motor

BELT CONVEYOR:

- Width x length, **1050 mm x 10135 mm** 3'5" x 33'3"
- Speed, **120 m/min** 393.7 ft/min
- Drive method, hydraulic piston motor



OPTIONAL EQUIPMENT

MAGNETIC SEPARATOR:

- Magnetic separator for primary conveyor, **900 mm** 35" wide



Magnetic Separator

MUCK CONVEYOR:

- Muck conveyor assembly can be folded by hydraulic cylinder, **4000 mm x 600 mm** 13'1" x 2'



Muck Conveyor

RADIO REMOTE CONTROLLER:



Function:

- Travel Left/Right/Forward/Reverse
- Crusher On/Off
- Feeder On/Off
- One-Touch Deceleration On/Off
- Emergency Shutoff
- Horn

Remote Controller

KOMATSU®