

KOMATSU

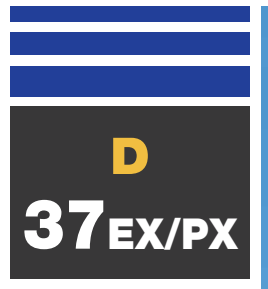

Crawler Dozer

D37EX/PX-22

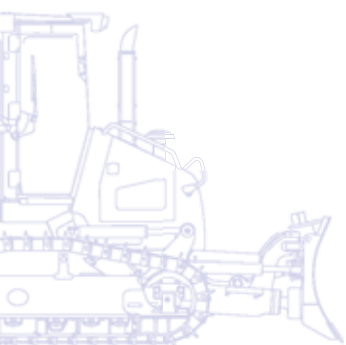

ENGINE POWER

67,7 kW / 90,8 HP @ 2.200 rpm

OPERATING WEIGHT

D37EX-22: 8.300 kg

D37PX-22: 8.650 kg

Walk-Around

The Komatsu D37EX/PX-22 dozers offer reliability, versatility - and the best value for your money. Their hydraulics, power train and frame, and all other major components are directly engineered by Komatsu, and work together to deliver optimal production levels. A super-slant nose and rear mounted cooler make them unique on the market today.

Unmatched visibility and safety

- Unique super-slant nose
- Cab-forward design
- Integrated ROPS/FOPS

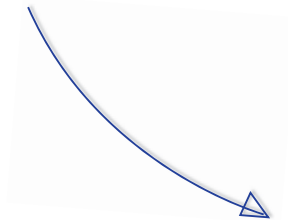

High productivity & low fuel consumption

- Powerful Komatsu ecot3 engine
- Meets EU Stage IIIA and EPA Tier III
- Highly efficient hydrostatic drive line
- High capacity Power Angle Tilt blade
- Electronically-controlled, hydraulically-driven fan



D37EX/PX-22

ENGINE POWER
67,7 kW / 90,8 HP @ 2.200 rpm

OPERATING WEIGHT
D37EX-22: 8.300 kg
D37PX-22: 8.650 kg

First-class operator comfort

- Outstanding 360° visibility
- Large and quiet pressurized cab
- Easy control with Palm Command Control System joysticks (PCCS)
- Air-suspended driver seat positioned close to centre of gravity



Easy maintenance

- Rear-mount radiator with swing-up hydraulic fan
- Monitor with self-diagnostic function
- Simple and convenient access to service points

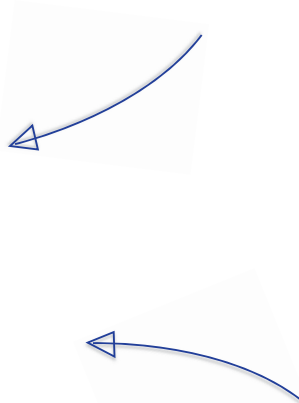

High reliability and durability

- Modular power train design
- Heavy-plate steel used throughout
- Main frame made with welded and cast parts

KOMTRAX

Komatsu Satellite
Monitoring System

Unmatched Visibility and Safety

The best view

A super slant nose gives the D37EX/PX-22 the best visibility of any dozers on the market. This unique feature dramatically increases efficiency and jobsite safety, with operators now always having full view of both the blade and the ripper and of objects close to them. The new cab-forward design, with integrated ROPS/FOPS and large glass windows, provides more room and places the operator closer to the blade, further improving visibility and comfort.

Safe and easy access

For a safer entry and exit - and maximum operator protection, the D37EX/PX-22 includes numerous hand-rails and access steps both inside and outside the cabin. It is also easier to refuel or clean windows, or to reach most service points.





High Productivity & Low Fuel Consumption

A clean, powerful engine

A powerful yet fuel-efficient engine makes the D37EX/PX-22 an outstanding performer both for dozing and ripping. This 67,7 kW / 90,8 HP ecot3 engine features a new combustion chamber design with optimised ignition and combustion timing. The operating pressure of the new common rail system was increased for improved injection and fuel efficiency. The air-to-air intercooler reduces the temperature of the compressed air supplied by the turbo charger to the cylinders, and further improves fuel consumption.

Meets EU Stage IIIA

The new Komatsu ecot3 technology reduces NOx and particle emissions, fuel consumption and noise level. The Komatsu SAA4D95LE-5 engine is certified for EU Stage IIIA and EPA Tier III emission regulations.

Highly efficient hydrostatic drive line

The hydrostatic drive line is a key factor in the performance of the D37EX/PX-22. It supplies high drawbar pull when needed and a highly fuel efficient drive line for grading and precision work. With a choice between two operating modes, the operator can select either “quick-shift” or “variable speed” to match a complete range of applications in the most economic and easy way.

Hydrostatic transmission (HST) control system

The unique, Komatsu-designed hydrostatic transmission controller monitors the engine output and working equipment or travel load. It controls the HST pumps and motors displacement to deliver optimum speed and drawbar pull. In addition, the controller provides ample power to both tracks when turning, enabling counter rotation at very low speeds and making the D37EX/PX-22 extremely manoeuvrable.

Automatic speed change

Komatsu HST controller always changes the travel speed automatically, depending on load or ground conditions, and efficient operations are facilitated – with no shift shocks. The dozer can work at the optimal speed and drawbar pull point, increasing productivity and fuel efficiency.



Komatsu SAA4D95LE-5 engine



1. Engine speed indication
2. Pre-set button reverse speed
3. Pre-set button Quick shift/variable speed setting



Efficient hydrostatic engine cooling fan

The cooling fan always runs at the lowest convenient speed. Rotation and velocity are electronically adjusted based on the temperature of the engine coolant and hydraulic oil. This reduces fuel consumption and operating noise levels, and requires less horsepower than a belt-driven fan. For extra efficiency, the fan also has a large air outlet surface, and the complete inlet area is protected by a fine grid, to prevent small particles from entering the fan area.



First-Class Operator Comfort

A smooth ride and lower noise levels

The cab on the D37EX/PX-22 was moved forward, and operators now sit closer to the centre of gravity of the machine. With the ripper still easily within eyeshot, they enjoy the best view of the blade, the lowest vibration levels and the highest stability of any dozer on the market. Silicon oil filled cab damper mounts isolate the operator compartment from the machine body and suppress vibrations, providing a quiet, comfortable operating environment. A new unique location for the radiator - at the rear of the machine - and the low speed of the hydraulically driven cooling fan further reduce noise levels.

Pressurised cab

The integrated ROPS/FOPS cab's new design and large, tinted windows ensure excellent visibility in all directions. Superior cab sealing, air filters and raised internal air pressure prevent dust from getting into the cab. In addition, the high-quality interior is lined with sound-absorbent material.

Easy operation control

The ergonomic Palm Command Control System (PCCS) provides efficient and comfortable steering of the machine, and the blade control joystick utilizes Proportional Pressure Control (PPC) for precise operations, excellent and easy grading jobs - and improved productivity.

Fully adjustable air suspension seat

The driver's seat and console are amongst the most important components of the driver's equipment. The comfortable, heavy-duty, air suspension seat, complete with headrest, gives the operator a secure and comfortable work environment.







High Reliability and Durability

Low drive undercarriage

Komatsu's low-drive undercarriage design is extraordinarily tough and offers excellent grading performance and stability. It features heavy-duty link assemblies with large-diameter bushings, substantial track link height and superior oil seals to maximise undercarriage durability and lifetime.

EX undercarriage

The EX undercarriage has been specially designed for working on hard ground. The small to medium-width shoes and heavy-duty link assembly ensure a large contact area between the machine and the ground for maximum stability, grading performance and undercarriage lifetime.

PX undercarriage

The PX undercarriage is ideal for working on soft surfaces. The wide shoes and heavy-duty, abrasion-resistant link assembly ensure a large contact area between the machine and the ground for maximum stability, grading performance and undercarriage lifetime.

Modular design

The D37EX/PX-22 was designed and manufactured to have low maintenance costs and a long lifetime. This was achieved mainly by reducing component complexity and with a strong modular design.

Improved rigidity and durability

Komatsu's monocoque track frame uses thicker box section material, and the machine's main frame is a highly-rigid simple hull with thick plates and steel casting. Both frames have fewer welded components and combine to provide increased strength, rigidity and durability to the D37EX/PX-22.



Modular design

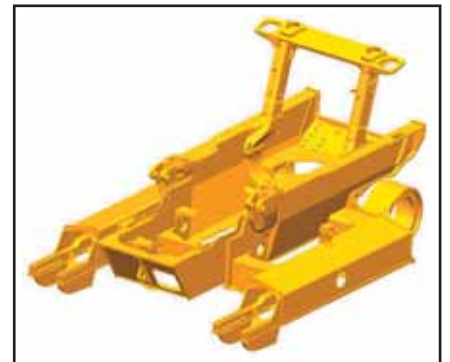

High-rigidity simple hull frame structure



*One-piece nose guard
Simplified high-rigidity structure with
thick plates reduces vibration and
increases the lifetime.*

Easy Maintenance

Simple and convenient service

Well located service doors allow convenient and safer ground access to daily service points. With the radiator located at the rear of the machine, engine fuel and oil filters can be easily accessed from the front of the engine compartment. Remote grease points facilitate lubrication of the C-frame pivots and angle cylinder bearing.

Engine protection

A large, double air filter ensures maximum engine protection. Fuel passes through a pre-filter with a water separator and a special final filter, maximising the engine's lifetime and minimising maintenance costs. The engine cooling fan position at the back of the machine significantly reduces dust levels at the engine air intake. This intake has a rain cap as standard and a turbo type pre cleaner in option for very dusty environments and to lengthen the intervals between the cleaning of the air filters.

Self-diagnostic monitor

The multi-function monitor panel displays the running time, engine revs, fuel level and water coolant temperature in real time. It also provides the operator with maintenance and service information, if oil filters need replacing or any abnormality occurs. In addition, it supplies Komatsu mechanics with detailed information, with no need for external service tools.

Protected hydraulic piping

Komatsu has designed the hydraulics of the working equipment so it minimises maintenance costs. All the hydraulic lines are well protected with special linings and embedded into the steel structures whenever possible.



Unique front-side access



Track roller guard, centre and end section





Reversible swing-up fan

The D37EX/PX-22 includes a swing-up fan with a gas strut-assisted lift locking system to provide easy access to the radiator, oil cooler, and charge air cooler. The operator can switch the hydraulic fan to “cleaning” mode so that it rotates in reverse at full speed to clean the radiators, reducing maintenance costs and improving fuel efficiency.



Komatsu Satellite Monitoring System



KOMTRAX™ is a revolutionary machine tracking system designed to save you time and money. You can now monitor your equipment anytime and anywhere. Use valuable machine data received via the KOMTRAX™ web site to optimise your maintenance planning and machine performances.

KOMTRAX™ can assist you with:

Full machine monitoring

Get detailed operation data to know when your machines are used and how productive they are.

Total Fleet Management

Keep track of the location of your machines at all times and discourage unapproved usage or theft.

Complete machine status

Receive warnings, alerts and cautions, via a web site or by e-mail, to help with maintenance planning and for longer machine life.

For further details on KOMTRAX™, please ask your Komatsu dealer for the latest KOMTRAX™ brochure.





Machine working time - With the "daily working record" chart, get precise engine running time data: when your machine was started and when it was shut down, as well as total engine running time.



Maintenance planning - To increase productivity and improve maintenance planning, alerts indicate when items such as filters or oil must be replaced.



Fleet location - The machine list instantly locates all your machines, even those in other countries.



Machine tracking during transport - When your machine is transported, KOMTRAX™ sends travel messages to the web site or by e-mail to inform you of its progress, and confirms when it reaches its destination.



Alarm notifications - You can receive notification of alarms both via the KOMTRAX™ website and by e-mail.



Added security - The "engine lock" feature allows to program when a machine's engine can be started. And with "geo-fence", KOMTRAX™ sends notification every time your machine moves in or out of a predetermined operating area.

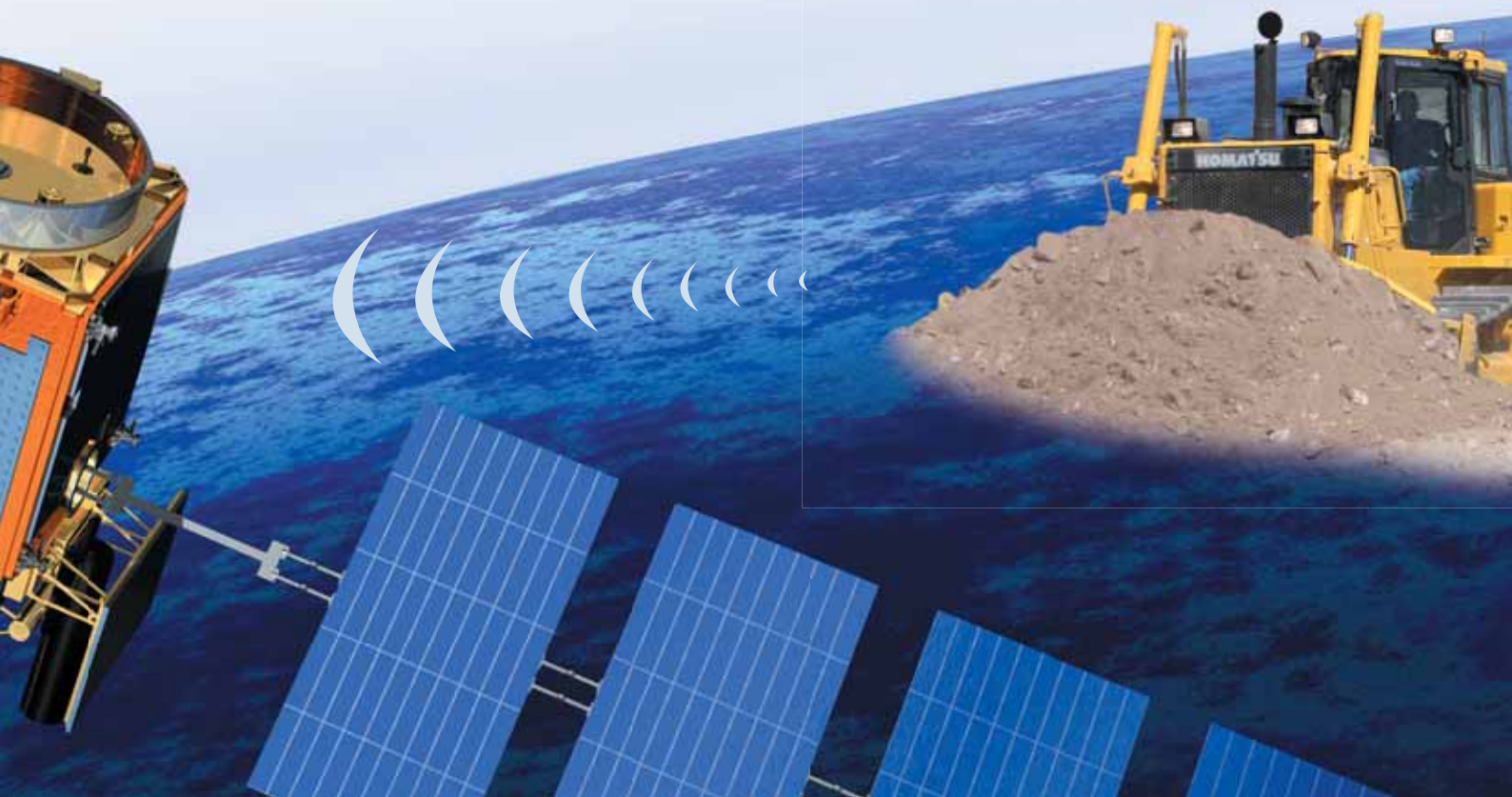

Komatsu blades

Komatsu uses a box blade design, offering the highest resistance for a low weight blade. This increases total blade manoeuvrability and machine balance. High-tensile-strength steel was incorporated into the front and sides of the blade for increased durability. The blade shape design makes it easy to handle a wide range of materials, offering good blade penetration combined with a low blade rolling resistance. Komatsu blades help to deliver excellent fuel efficiency.

Straight Power Angle Tilt blade

The straight Power Angle Tilt blade (PAT), offers a wide range of working modes. The new centreball design, with a large ball diameter, offers a strong and durable solution for the blade attachment to the Inpat frame reducing maintenance costs.

Komatsu rippers

Komatsu rippers were designed to combine the highest productivity with a long lifetime. The shank is fitted with special wear parts that increase longevity, and offer the best penetration in various types of materials.

Multishank parallelogram ripper (EX) (option)

The multishank parallelogram ripper has 3 ripper shanks as standard, but can be easily converted to a giant or two-shank ripper, depending on job conditions. The strong parallelogram design offers straight shank movement, adapted for different jobsite applications.

Komatsu-Topcon machine control systems

Automatic blade movements on a dozer greatly improve dozing productivity and grading accuracy. They also allow operators to work faster and more safely with a reduced workload. Komatsu-Topcon machine control systems are the best way to automate blade movements. Depending on the control system used, blade movement can be monitored or fully automated. As a result, even inexperienced operators work much faster and deliver a high-quality final graded area. All the information from the laser or GPS systems is constantly available on an in-cab display, clearly showing the slope and elevation.

Two different systems for Komatsu dozers are available.

Two-dimensional (2D): allow creation of flat areas, possibly combined with a slope depending on the configuration. These systems are based on one or two laser signal receivers and/or a slope sensor installed on the dozer blade.

Three-dimensional (3D): allow any complicated landscape design to be made. This requires GPS receivers, and can be extended with a laser zone system for millimetre accuracy.





Specifications

ENGINE

Model Komatsu SAA4D95LE-5
 Common rail direct injection, water-cooled, emissionised, turbocharged, after-cooled diesel

Engine power
 at rated engine speed 2.200 rpm
 ISO 14396 67,7 kW/90,8 HP
 ISO 9249 (net engine power) 66,0 kW/88,5 HP

No. of cylinders 4
 Bore x stroke 95 x 115 mm
 Displacement 3,26 ltr
 Governor All-speed, electronic
 Fan drive type Hydraulic
 Lubrication system
 Method Gear pump, force lubrication
 Filter Full flow

HYDROSTATIC TRANSMISSION

Dual-path, hydrostatic transmission provides infinite speed changes up to 8,5 km/h. The variable capacity travel motors allow the operator to select the optimum speed to match specific jobs. Travel control lock lever and neutral switch.

MAX. TRAVEL SPEEDS

Quick shift mode	Forward	Reverse
1st	0 - 3,4 km/h	0 - 4,1 km/h
2nd	0 - 5,6 km/h	0 - 6,5 km/h
3rd	0 - 8,5 km/h	0 - 8,5 km/h

Variable speed mode	Forward	Reverse
	0 - 8,5 km/h	0 - 8,5 km/h

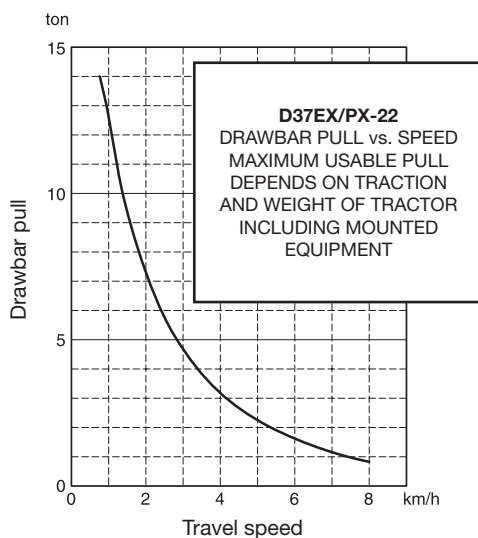

FINAL DRIVE

Type Planetary gear, double-reduction
 Sprocket Bolt-on for easy replacement

STEERING SYSTEM

Type Hydrostatic Steering System (HST)
 Steering control PCCS-lever
 Service brakes Hydraulic dynamic brake, pedal-controlled
 Minimum turning radius (pivot turn)
 D37EX-22 2,0 m
 D37PX-22 2,2 m
 As measured by track marks on the ground.

UNDERCARRIAGE

Suspension Rigid type
 Track roller frame... Monocoque, large section, durable construction
 Tracks Lubricated tracks, fully sealed
 Track tension Combined spring and hydraulic unit
 Number of shoes (each side) 41
 Grouser height (single grouser) 47 mm
 Track rollers (each side) 6
 Shoe width (standard)
 D37EX-22 400 mm
 D37PX-22 600 mm
 Ground contact area
 D37EX-22 17.900 cm²
 D37PX-22 26.900 cm²
 Ground pressure
 D37EX-22 0,46 kg/cm²
 D37PX-22 0,32 kg/cm²
 Including PAT blade, hitch, steel cab, operator, rated capacity of lubricant, coolant, and full fuel tank.

OPERATING WEIGHT (APPR.)

Including PAT blade, hitch, steel cab, operator, rated capacity of lubricant, coolant, and full fuel tank.
 D37EX-22 8.300 kg
 D37PX-22 8.650 kg

SERVICE REFILL CAPACITIES

Cooling system 18 ltr
 Fuel tank 195 ltr
 Engine oil 11 ltr
 Hydraulic tank 60 ltr
 Final drive (each side) 3,5 ltr

ENVIRONMENT

Engine emissions Fully complies with EU Stage IIIA and EPA Tier III exhaust emission regulations

Noise levels
 LwA external 107 dB(A) (2000/14/EC Stage II)
 LpA operator ear 77 dB(A) (ISO 6396 dynamic test)

Vibration levels (EN 12096:1997)*
 Hand/arm ≤ 2,5 m/s² (uncertainty K = 1,0 m/s²)
 Body ≤ 0,5 m/s² (uncertainty K = 0,2 m/s²)
 * for the purpose of risk assessment under directive 2002/44/EC, please refer to ISO/TR 25398:2006.

DIMENSIONS

	D37EX-22	D37PX-22
A	1.280 mm	1.280 mm
B	2.710 mm	3.250 mm
B*	—	2.875 mm
C	370 mm	440 mm
C*	—	390 mm
D	2.635 mm	2.635 mm
E	880 mm	870 mm
F	400 mm	390 mm
G	2.240 mm	2.240 mm
H	4.190 mm	4.175 mm
I	1.785 mm	1.785 mm
J	2.945 mm	2.945 mm
K	2.750 mm	2.750 mm
L	47 mm	47 mm
M	1.510 mm	1.650 mm
N	400 mm	600 mm

O	1.910 mm	2.250 mm
P	2.490 mm	2.980 mm
P*	—	2.640 mm
Q	4.720 mm	4.820 mm
Q*	—	4.740 mm

* Narrow blade for D37PX-22

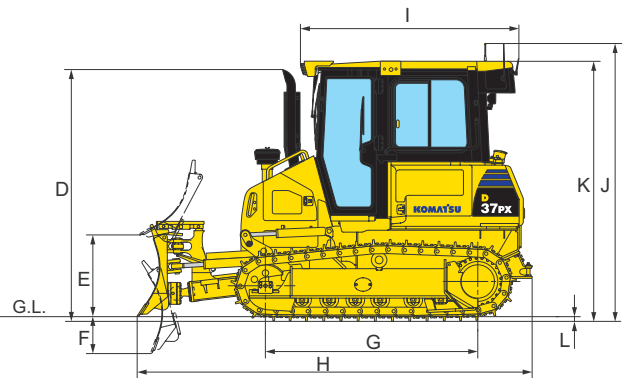
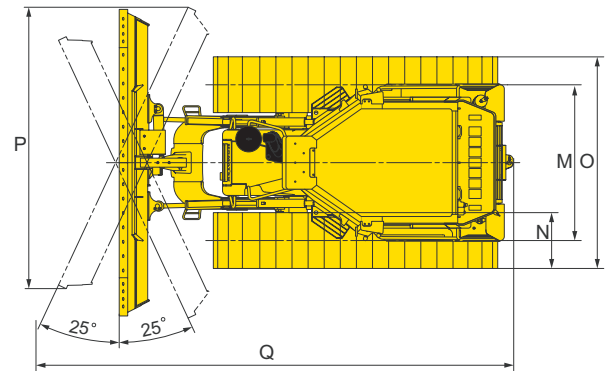
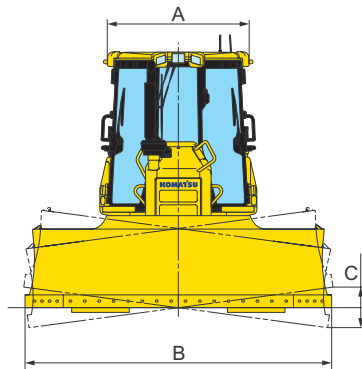

Ground clearance: 315 mm

HYDRAULIC SYSTEM

Type	CLSS (closed-centre load sensing system)
All spool valves externally mounted beside the hydraulic tank.	
Maximum pump flow	99 ltr/min
Relief valve setting	280 kg/cm ²
Spool control valve positions	
Blade lift	Raise, hold, lower, and float
Blade tilt	Right, hold, and left
Additional control valve positions for ripper	
Ripper lift	Raise, hold, and lower
Hydraulic cylinders Double-acting, piston type	
No. of cylinders × bore	
Blade lift	2 × 75 mm
Blade tilt	1 × 90 mm
Blade angle	2 × 80 mm
Ripper lift	1 × 105 mm

RIPPER EQUIPMENT

Multishank ripper	
Type	Hydraulically controlled parallelogram ripper
No. of shanks	3
Weight (including hydraulic control unit)	695 kg
Beam length	620 mm
Maximum lift above ground	385 mm
Maximum digging depth	335 mm

DOZER EQUIPMENT

	Overall length with dozer	Blade width × height	Maximum lift above ground	Maximum drop below ground	Maximum tilt adjustment	Blade angle
1,77 m ³ PAT blade (EX)	4.190 mm	2.710 mm × 860 mm	880 mm	400 mm	370 mm	25°
1,95 m ³ PAT blade (PX)	4.175 mm	3.250 mm × 830 mm	870 mm	390 mm	440 mm	25°
1,76 m ³ narrow PAT blade (PX)	4.175 mm	2.875 mm × 830 mm	870 mm	390 mm	390 mm	25°

Blade capacities are based on the SAE recommended practice J1265.

Crawler Dozer

D37EX/PX-22

Standard and Optional Equipment

ENGINE AND RELATED PARTS

Komatsu SAA4D95LE-5 turbocharged direct injection diesel engine	●
EU Stage IIIA/EPA Tier III compliant	●
Fuel pre-filter (10 micron) and fuel filter (2 micron)	●
Engine cooling fluid corrosion resistor	●
Alternator 60 A	●
Starter motor 4,5 kW/24 V	●
Batteries 92 Ah/2 × 12 V	●

TRANSMISSION AND BRAKES

Electronically controlled HST	●
Palm lever steering control (PCCS)	●
Quick shift selection system	●
Variable speed mode	●
Reverse speed presets	●
Decelerator pedal	●
Combined inch/brake pedal	●

UNDERCARRIAGE

Single grouser heavy-duty shoes (EX: 400 mm; PX: 600 mm)	●
Heavy-duty link assembly, sealed and lubricated	●
Track roller guard, centre and end section	●
Full length track roller guard	○
Single grouser heavy-duty shoes 460 mm (EX)	○

LIGHTING SYSTEM

Working lights, 3 cab roof front, 1 cab roof rear	●
---	---

SERVICE AND MAINTENANCE

Swing-out hydrostat-driven radiator fan with reversing function	●
Dry type air cleaner, double element with dust indicator and evacuator	●
Water separator	●
Electronic monitor panel with self-diagnostic function and maintenance display	●
KOMTRAX™ - Komatsu satellite monitoring system	●
Tool kit	●

CABIN

Air suspension seat: fabric, reclining, high backrest	●
Seat belt	●
High mount footrest	●
Air conditioner	●
Pre radio installation kit (12 V, antenna, loudspeakers)	●
12 Volt power supply (120 W)	●
Viscous cab mounts	●
Rear-view mirror (inside cab)	●
Wiper front window	●
Wiper rear window	●
Wipers doors	●
Cup holder	●
Lunch box holder	○

HYDRAULIC SYSTEM

Hydraulics for dozing blades	●
Mono lever blade control	●
Hydraulics for ripper (EX only)	○

SAFETY EQUIPMENT

Steel cab, meets ISO 3471 and SAE J1040, APR88 ROPS standards, as well as ISO 3449 FOPS standards	●
Horn	●
Locks, filter caps and covers	●
Back-up alarm	●
Fire extinguisher	○

ATTACHMENTS

Front pull hook	●
Hitch (not with ripper)	●
Swing type drawbar	○

DOZER EQUIPMENT

1,77 m ³ PAT blade (EX)	○
1,95 m ³ PAT blade (PX)	○
1,76 m ³ narrow PAT blade (PX)	○
Multishank parallelogram ripper (EX only)	○
Komatsu-Topcon machine control systems	○

Further equipment on request

- standard equipment
- optional equipment

Your Komatsu partner:

KOMATSU

**Komatsu Europe
International NV**
Mechelsesteenweg 586
B-1800 VILVOORDE (BELGIUM)
Tel. +32-2-255 24 11
Fax +32-2-252 19 81
www.komatsu.eu

EESS019202 09/2010

Materials and specifications are subject to change without notice.
KOMATSU is a trademark of Komatsu Ltd. Japan.