

KOMATSU

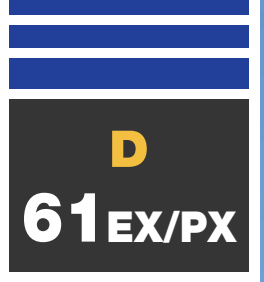

Crawler Dozer

D61EX/PX-23

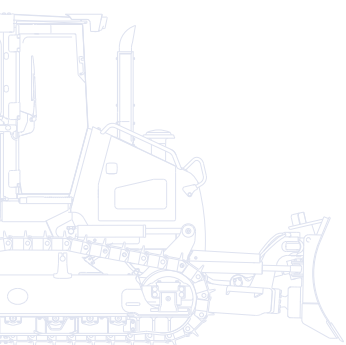

ENGINE POWER

126 kW / 169 HP @ 2.200 rpm

OPERATING WEIGHT

D61EX-23 17.780 kg

D61PX-23 18.660 kg

Walk-Around

The Komatsu D61EX/PX-23 dozer offers reliability, versatility - and the best value for your money. Hydraulics, power train and frame, as well as all other major components are directly engineered and manufactured by Komatsu, and they work together perfectly to deliver optimal production levels. A super-slant nose and rear mounted cooler make this dozer unique on the market today. The D61-23 is equipped with a factory-fitted Plug and Play provision kit for easy installation of Topcon 2D and 3D blade control systems, making this Komatsu dozer your perfect partner for automatic applications.

Unmatched visibility and safety

- Unique super-slant nose
- Cab-forward design
- Integrated ROPS/FOPS
- Rear view camera system

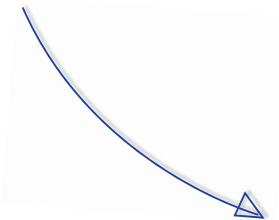

High productivity & low fuel consumption

- Low consumption EU Stage IIIB engine
- Highly efficient hydrostatic drive line
- Straight Power Angle Tilt blade with adjustable pitch
- Electronically-controlled, hydraulically-driven fan
- Komatsu-Topcon Plug & Play provisions

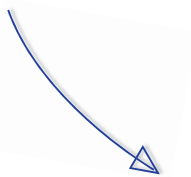

D61EX/PX-23

ENGINE POWER
126 kW / 169 HP @ 2.200 rpm

OPERATING WEIGHT
D61EX-23 17.780 kg
D61PX-23 18.660 kg

First-class operator comfort

- Outstanding 360° visibility
- Large and quiet pressurized cab
- Easy control with Palm Command Control System joysticks (PCCS)
- Air-suspended driver seat positioned close to centre of gravity



Easy maintenance

- Rear-mount radiator with swing-up hydraulic fan
- Monitor with self-diagnostic function
- Simple and convenient access to service points



Complimentary maintenance program for customers

KOMTRAX

Komatsu Wireless Monitoring System

High reliability and durability

- New Komatsu PLUS undercarriage (standard)
- Modular power train design
- Heavy-plate steel used throughout
- Main frame made with welded and cast parts



Unmatched Visibility and Safety

The best view

A super slant nose gives the D61EX/PX-23 the best visibility of any dozers on the market. This unique feature dramatically increases efficiency and jobsite safety, with operators now always having full view of both the blade and the ripper and of objects close to them. The new cab-forward design, with integrated ROPS/FOPS and large glass windows, provides more room and places the operator closer to the blade, further improving visibility and comfort.

Safe and easy access

For a safer entry and exit - and maximum operator protection, the D61EX/PX-23 includes numerous hand-rails and access steps both inside and outside the cabin. It is also easier to refuel or clean windows, or to reach most service points.



Rear view camera system





High Productivity & Low Fuel Consumption

New Komatsu engine technology

The powerful and fuel-efficient Komatsu SAA6D107E-2 engine in the D61EXPX-23 delivers 126 kW/ 169 HP and is EU Stage IIIB certified. To maximise power, fuel efficiency and emission compliance, it is turbo charged and features direct fuel injection, air-to-air after cooling and cooled EGR.

Highly efficient hydrostatic drive line

The hydrostatic drive line is a key factor in the performance of the D61EX/PX-23 dozer. It supplies high drawbar pull when needed and a highly fuel efficient drive line for grading and precision work. With a choice between two operating modes, the operator can select either “quick-shift” or “variable speed” to match a complete range of applications in the most economic and easy way.

Komatsu Diesel Particulate Filter (KDPF)

Komatsu's high efficiency DPF captures more than 90% of particulate matter. It includes a special oxidation catalyst with fuel injection system that can incinerate trapped particulates by either active or passive re-generation with no need to interrupt machine operations.

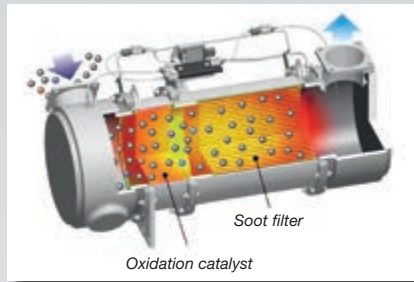

Exhaust Gas Recirculation (EGR)

Cooled EGR is a technology well-proven in current Komatsu engines. The increased capacity of the EGR cooler now ensures very low NOx emissions and a better engine performance.

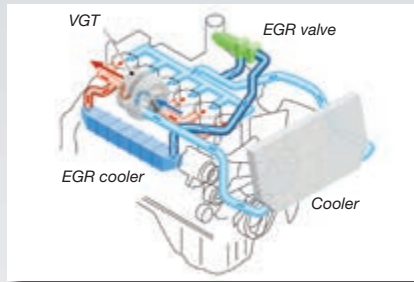

Variable Geometry Turbo (VGT)

The VGT provides optimal air flow to the engine combustion chamber under all speed and load conditions. Exhaust gas is cleaner, fuel economy is improved while machine power and performance are maintained.

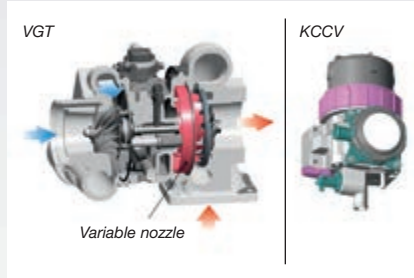

Komatsu Closed Crankcase Ventilation (KCCV)

Crankcase emissions (blow-by gas) are passed through a CCV filter. The oil mist trapped in the filter is returned back to the crankcase while the filtered gas is returned to the air intake.

High-Pressure Common Rail (HPCR)

To achieve complete fuel burn and lower exhaust emissions, the heavy duty High-Pressure Common Rail fuel injection system is computer controlled to deliver a precise quantity of pressurised fuel into the redesigned engine combustion chamber by multiple injections.

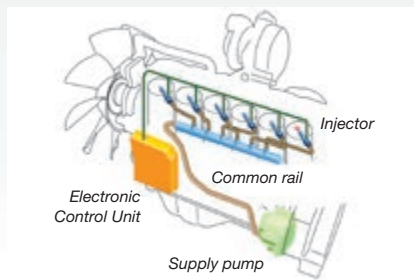

Hydrostatic transmission (HST) control system

The unique, Komatsu-designed hydrostatic transmission controller monitors the engine output and working equipment or travel load. It controls the HST pumps and motors displacement to deliver optimum speed and drawbar pull. In addition, the controller provides ample power to both tracks when turning, enabling counter rotation at very low speeds and making the D61EX/PX-23 extremely manoeuvrable.



Automatic speed change

Komatsu HST controller always changes the travel speed automatically, depending on load or ground conditions, and efficient operations are facilitated – with no shift shocks. The dozer can work at the optimal speed and drawbar pull point, increasing productivity and fuel efficiency.

Efficient hydrostatic engine cooling fan

The cooling fan always runs at the lowest convenient speed. Rotation and velocity are electronically adjusted based on the temperature of the engine coolant and hydraulic oil. This reduces fuel consumption and operating noise levels, and requires less horsepower than a belt-driven fan.

For extra efficiency, the fan also has a large air outlet surface, and the complete inlet area is protected by a fine grid, to prevent small particles from entering the fan area.

First-Class Operator Comfort

A smooth ride and lower noise levels

The cab on the D61EX/PX-23 was moved forward, and operators now sit closer to the centre of gravity of the machine. With the ripper still easily within eyeshot, they enjoy the best view of the blade, the lowest vibration levels and the highest stability of any dozer on the market. Silicon oil filled cab damper mounts isolate the operator compartment from the machine body and suppress vibrations, providing a quiet, comfortable operating environment. A new unique location for the radiator - at the rear of the machine - and the low speed of the hydraulically driven cooling fan further reduce noise levels.

Large TFT colour multi monitor

A large user-friendly colour monitor enables safe, accurate and smooth work. It provides on-hand data to continuously improve productivity and fuel consumption. Multilingual and with all essential information available at a glance, it features simple and easy to operate switches and multifunction keys that provide the operator with fingertip access to a wide range of functions and operating information.

Easy operation control

The ergonomic Palm Command Control System (PCCS) provides efficient and comfortable steering of the machine, and the blade control joystick utilizes Proportional Pressure Control (PPC) for precise operations, excellent and easy grading jobs - and improved productivity.

Fully-adjustable, heated air suspension seat

The driver's seat and console are amongst the most important components of the driver's equipment. The comfortable, heavy-duty, air suspension seat, complete with headrest, gives the operator a secure and comfortable work environment.

Pressurised cab

The integrated ROPS/FOPS cab's new design and large, tinted windows ensure excellent visibility in all directions. Superior cab sealing, air filters and raised internal air pressure prevent dust from getting into the cab. In addition, the high-quality interior is lined with sound-absorbent material.



Large TFT colour multi monitor



Palm Command Control System (PCCS)



Combined decelerator/brake pedal



Auxiliary input (MP3 jack)



High Reliability and Durability

Low-drive “PLUS” undercarriage

Komatsu’s new low-drive Parallel Link Undercarriage System (PLUS) is extraordinarily tough, with an excellent grading performance and stability. It features PLUS link assemblies, a new highly reliable floating bushing concept, substantial track link height, superior oil seals and newly designed track guards to maximise undercarriage durability. For easier servicing, the equalizer bar’s centre pin can be remotely greased. The segmented sprockets can be changed individually and by hand, so a single mechanic can carry out replacements at the jobsite.

EX undercarriage

The EX undercarriage has been specially designed for working on hard ground. The small to medium-width shoes and PLUS link assembly ensure a large contact area between the machine and the ground for maximum stability, grading performance and undercarriage lifetime.

PX undercarriage

The PX undercarriage is ideal for working on soft surfaces. The wide shoes and PLUS link assembly ensure a large contact area between the machine and the ground for maximum stability, grading performance and undercarriage lifetime.

Modular design

D61EX/PX-23 was designed and manufactured to have low maintenance costs and a long lifetime. This was achieved mainly by reducing component complexity and with a strong modular design.

Improved rigidity and durability

Komatsu’s monocoque track frame uses thicker box section material, and the machine’s main frame is a highly-rigid simple hull with thick plates and steel casting. Both frames have fewer welded components and combine to provide increased strength, rigidity and durability to the D61EX/PX-23.

Self-adjusting idler support

The self-adjusting idler support provides constant and even tension on idler guide plates. It reduces noise levels and vibrations and increases undercarriage life.

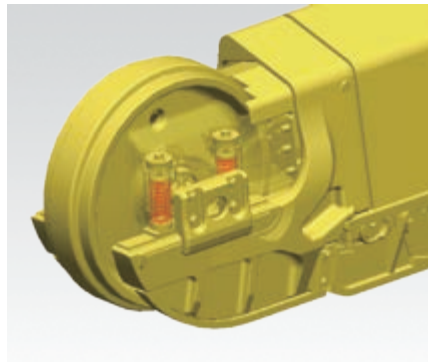

Self-adjusting idler support

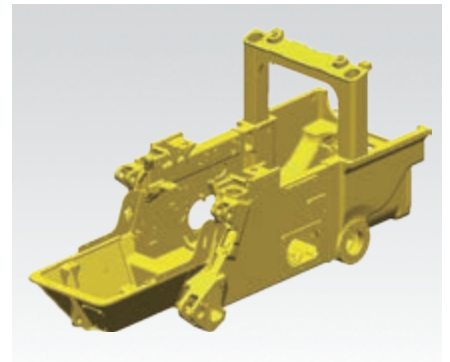

High-rigidity simple hull frame structure



*The new Komatsu PLUS undercarriage:
When conventional undercarriages are
long gone, the PLUS undercarriage
keeps going strong.*

Easy Maintenance

Simple and convenient service

Well located service doors allow convenient and safer ground access to daily service points. With the radiator located at the rear of the machine, engine fuel and oil filters can be easily accessed from the front of the engine compartment. Remote grease points facilitate lubrication of the C-frame pivots and angle cylinder bearing.

Self-diagnostic monitor

The multi-function monitor panel displays the running time, engine revs, fuel level and water coolant temperature in real time. It also provides the operator with maintenance and service information, if oil filters need replacing or any abnormality occurs. In addition, it supplies Komatsu mechanics with detailed information, with no need for external service tools.

Engine protection

A large, double air filter ensures maximum engine protection. Fuel passes through a pre-filter with a water separator and a special final filter, maximising the engine's lifetime and minimising maintenance costs. The engine cooling fan position at the back of the machine significantly reduces dust levels at the engine air intake. This intake has a rain cap as standard and a turbo type pre cleaner in option for very dusty environments and to lengthen the intervals between the cleaning of the air filters.



Komatsu CARE is a complimentary maintenance program for Komatsu customers that comes as standard with every new Komatsu EU Stage IIIB construction machine. For the first 3 years or 2,000 hours it covers factory-scheduled maintenance, performed by Komatsu-trained technicians with Komatsu Genuine parts. It also offers up to a maximum of 2 complimentary Komatsu Diesel Particulate Filter (KDPF) exchange units and a KDPF warranty for the first 5 years or 9,000 hours.



Unique front-side access

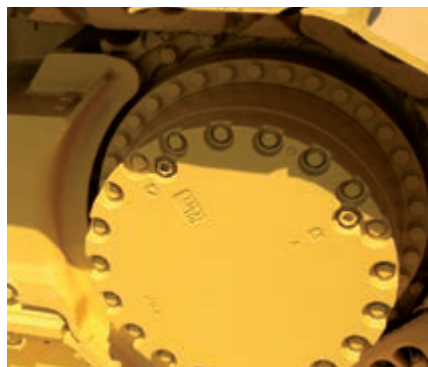

Segmented sprocket





Reversible swing-up fan

The D61EX/PX-23 includes a swing-up fan with a gas strut-assisted lift locking system to provide easy access to the radiator, oil cooler, and charge air cooler. The operator can switch the hydraulic fan to “cleaning” mode so that it rotates in reverse at full speed to clean the radiators, reducing maintenance costs and improving fuel efficiency.



Komatsu Wireless Monitoring System

The easy way to higher productivity

KOMTRAX™ is the latest in wireless monitoring technology. It delivers insightful and cost saving information about your fleet and equipment and offers you a wealth of information to facilitate peak machine performance. By creating a tightly integrated web of support it allows pro active and preventive maintenance and helps you to efficiently run a business.

Knowledge

You get quick answers to basic and critical questions about your machines - what they're doing, when they did it, where they're located, how they can be used more efficiently, and when they need to be serviced. Performance data is relayed by satellite from your machine to your computer and to your local Komatsu distributor - who's readily available for expert analysis and feedback.

Convenience

KOMTRAX™ helps to conveniently manage your fleet on the web, wherever you are. Data is analysed and packaged specifically for easy and intuitive viewing in maps, lists, graphs and charts. You can anticipate the type of service and parts your machines could require, or troubleshoot problems before Komatsu technicians arrive on site.





Power

The detailed information that KOMTRAX™ puts at your fingertips 24 hours a day, 7 days a week gives you the power to make better daily and long-term strategic decisions. You can anticipate problems, customize maintenance schedules, minimize downtime and keep your machines where they belong – working on the job site.

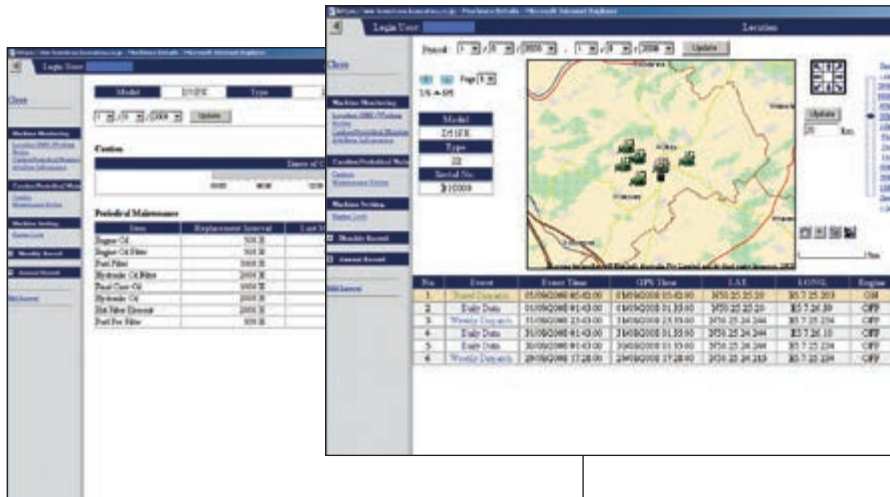

Through the web application, a variety of search parameters are available to quickly find information about specific machines based on key factors such as utilization rates, age, various notification messages, and more.

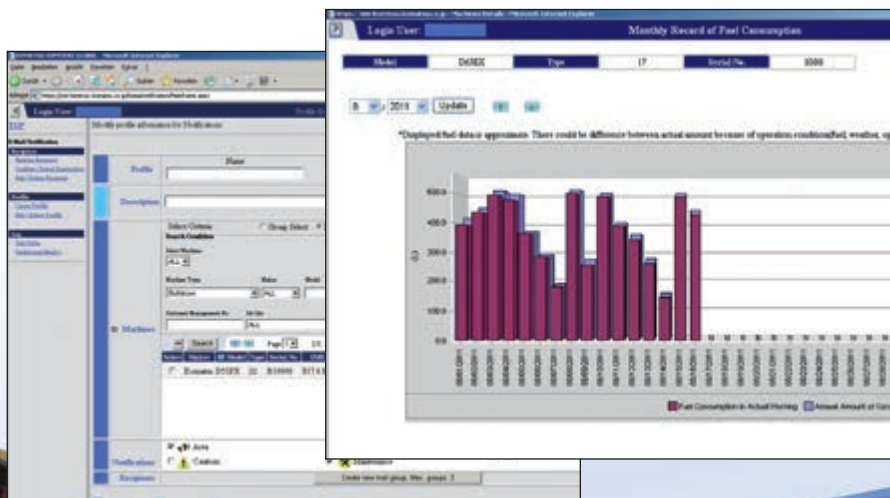

A simple chart shows the machine's fuel consumption and helps you to calculate total costs for a job site and conveniently schedule fuel deliveries.

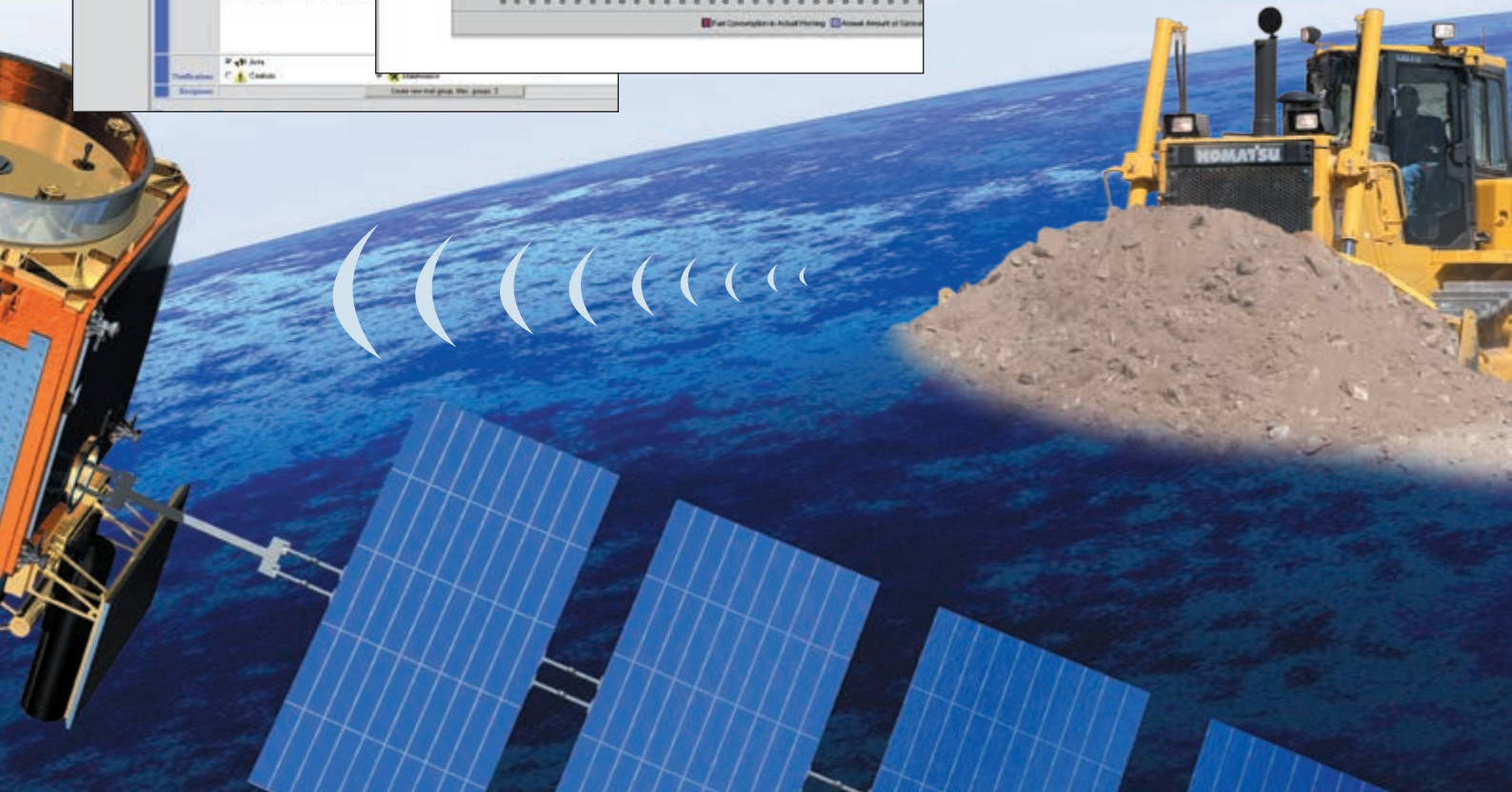

Komatsu blades

Komatsu uses a box blade design, offering the highest resistance for a low weight blade. This increases total blade manoeuvrability and machine balance. High-tensile-strength steel was incorporated into the front and sides of the blade for increased durability. The blade shape design makes it easy to handle a wide range of materials, offering good blade penetration combined with a low blade rolling resistance. Komatsu blades help to deliver excellent fuel efficiency.

Straight Power Angle Tilt blade with adjustable pitch

The straight Power Angle Tilt blade (PAT), offers a wide range of working modes. The new centreball design, with a large ball diameter, offers a strong and durable solution for the blade attachment to the Inpat frame reducing maintenance costs. A fold-up version of the blade for the PX machines guarantees a transport width of 3 metres and easy transportation between job-sites.

Komatsu rippers

Komatsu rippers were designed to combine the highest productivity with a long lifetime. The shank is fitted with special wear parts that increase longevity, and offer the best penetration in various types of materials.

Multishank parallelogram ripper (EX) (option)

The multishank parallelogram ripper has 3 ripper shanks as standard, but can be easily converted to a giant or two-shank ripper, depending on job conditions. The strong parallelogram design offers straight shank movement, adapted for different jobsite applications.

Komatsu-Topcon Plug & Play provisions

The D61-23 comes factory-fitted with “Plug & Play” provisions for the easy installation of Topcon control systems. Specific brackets and plug-in points on the blade, the machine and in the cab allow the quick mounting of all required components. Komatsu-Topcon machine control systems are an ideal way to automate blade movements. All the information from the laser or GPS systems is constantly available on the in-cab display, clearly showing the slope and elevation.

The software is user-friendly and intuitive and greatly reduces the workload by allowing precise and safe operations. Combined with the D61-23 dozer's high grading efficiency, fuel consumption is reduced to a minimum. Komatsu-Topcon machine control provides high operator satisfaction and gives you the best value for your money.

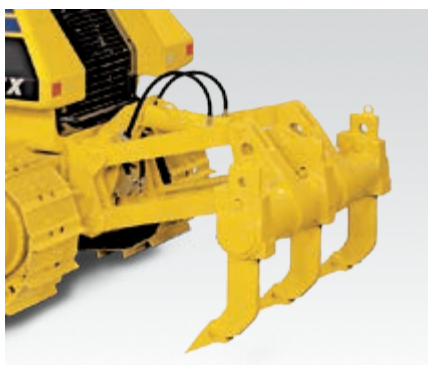
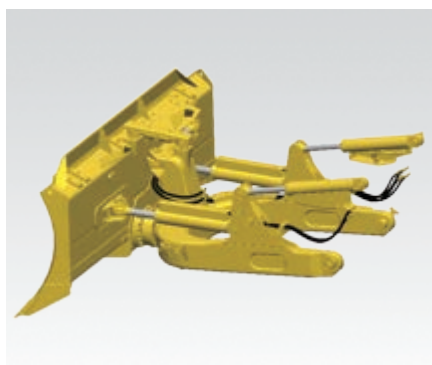



Specifications

ENGINE

Model Komatsu SAA6D107E-2
Common rail direct injection, water-cooled, emissionised, turbocharged, after-cooled diesel

Engine power
at rated engine speed 2.200 rpm
ISO 14396 126 kW/169 HP
ISO 9249 (net engine power) 125 kW/168 HP

No. of cylinders 6
Bore × stroke 107 mm × 124 mm
Displacement 6,69 ltr
Governor All-speed, electronic
Fan drive type Hydraulic
Lubrication system
Method Gear pump, force lubrication
Filter Full flow

HYDROSTATIC TRANSMISSION

Dual-path, hydrostatic transmission provides infinite speed changes up to 9,0 km/h. The variable capacity travel motors allow the operator to select the optimum speed to match specific jobs. Travel control lock lever and neutral switch.

MAX. TRAVEL SPEEDS

Quick shift mode	Forward	Reverse
1st	0 - 3,4 km/h	0 - 4,1 km/h
2nd	0 - 5,6 km/h	0 - 6,5 km/h
3rd	0 - 9,0 km/h	0 - 9,0 km/h

Variable speed mode	Forward	Reverse
	0 - 9,0 km/h	0 - 9,0 km/h

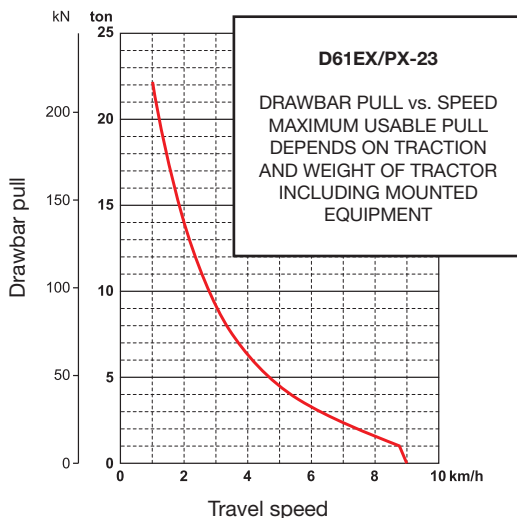

FINAL DRIVE

Type Planetary gear, double-reduction
Sprocket Segmented sprocket teeth
are bolt-on for easy replacement

STEERING SYSTEM

Type Hydrostatic Steering System (HST)
Steering control PCCS-lever
Minimum turning radius (counter-rotation)
D61EX-23 2,1 m
D61PX-23 2,3 m
As measured by track marks on the ground.

UNDERCARRIAGE

Suspension Oscillating equaliser bar and pivot shaft
Track roller frame Monocoque, large section,
durable construction

Tracks PLUS link assembly
Track tension Combined spring and hydraulic unit
Number of shoes (each side) 46
Grouser height (single grouser) 58 mm
Track rollers (each side) 8
Carrier rollers (each side) 2
Shoe width (standard)
D61EX-23 600 mm
D61PX-23 860 mm

Ground contact area
D61EX-23 37.980 cm²
D61PX-23 54.440 cm²

Ground pressure
D61EX-23 0,47 kg/cm²
D61PX-23 0,34 kg/cm²

OPERATING WEIGHT (APPR.)

Including PAT blade, steel cab, operator, rated capacity of lubricant, coolant, and full fuel tank.
D61EX-23 17.780 kg
D61PX-23 18.660 kg

SERVICE REFILL CAPACITIES

Fuel tank 372 ltr
Radiator 45 ltr
Engine oil 27 ltr
Final drive (each side) 8,1 ltr
Hydraulic tank 101 ltr

ENVIRONMENT

Engine emissions Fully complies with EU Stage IIIB exhaust emission regulations

Noise levels
LwA external 107 dB(A) (2000/14/EC Stage II)
LpA operator ear 78 dB(A) (ISO 6396 dynamic test)

Vibration levels (EN 12096:1997)*
Hand/arm ≤ 2,5 m/s² (uncertainty K = 0,8 m/s²)
Body ≤ 0,5 m/s² (uncertainty K = 0,2 m/s²)

* for the purpose of risk assessment under directive 2002/44/EC, please refer to ISO/TR 25398:2006.



DIMENSIONS

	D61EX-23	D61PX-23
A	3.250 mm	3.860 mm
B	435 mm	515 mm
C	1.195 mm	1.155 mm
D	1.025 mm	1.025 mm
E	580 mm	580 mm
F	3.165 mm	3.165 mm
G	5.480 mm	5.480 mm
H	3.180 mm	3.180 mm
I	57,5 mm	57,5 mm
J	1.900 mm	2.130 mm
K	600 mm	860 mm
L	2.500 mm	2.990 mm
M	2.980 mm	3.530 mm
N	6.100 mm	6.220 mm

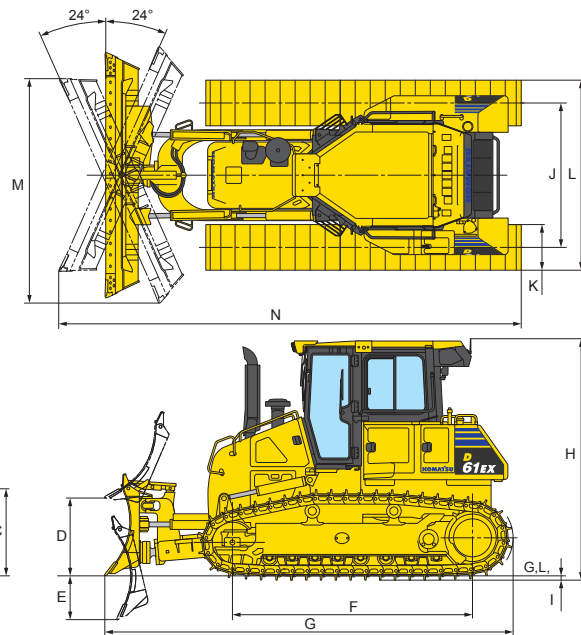
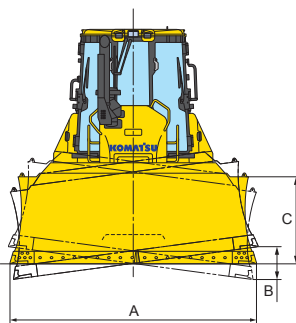

Ground clearance: 390 mm (+ 58 mm grouser height)

HYDRAULIC SYSTEM

Type.....CLSS (closed-centre load sensing system)
 All spool valves externally mounted beside the hydraulic tank.
 Maximum pump flow.....171 ltr/min
 Relief valve setting280 kg/cm²
 Spool control valve positions
 Blade lift.....Raise, hold, lower, and float
 Blade tilt..... Right, hold, and left
 Additional control valve positions for ripper
 Ripper lift Raise, hold, and lower
 Hydraulic cylinders..... Double-acting, piston
 No. of cylinders × bore
 Blade lift.....2 × 100 mm
 Blade tilt.....1 × 120 mm
 Blade angle.....2 × 110 mm

RIPPER EQUIPMENT

Multishank ripper
 Type..... Hydraulically controlled parallelogram ripper
 No. of shanks3
 Weight (including hydraulic control unit) 1.780 kg
 Beam length2.170 mm
 Maximum lift above ground.....565 mm
 Maximum digging depth665 mm

DOZER EQUIPMENT

	Overall length with dozer	Blade width × height	Maximum lift above ground	Maximum drop below ground	Maximum tilt adjustment	Additional weight
3,4 m ³ PAT blade (EX)	5.480 mm	3.250 mm × 1.195 mm	1.025 mm	580 mm	435 mm	0 kg
3,8 m ³ PAT blade (PX)	5.480 mm	3.860 mm × 1.155 mm	1.025 mm	580 mm	515 mm	0 kg
3,8 m ³ foldable PAT blade (PX)*	5.480 mm	3.860 mm × 1.155 mm Folding width: 2.960 mm	1.025 mm	580 mm	515 mm	+ 240 kg

Blade capacities are based on the SAE recommended practice J1265.

* Applicable only to light duty jobs.

Crawler Dozer

D61EX/PX-23

Standard and Optional Equipment

ENGINE AND RELATED PARTS

Komatsu SAA6D107E-2 turbocharged common rail direct injection diesel engine	●
EU Stage IIIB compliant	●
Fuel pre-filter (10 micron) and fuel filter (2 micron)	●
Exhaust pipe with elbow	●
Intake pipe with rain cap	●
Alternator 24 V/60 A	●
Starter motor 5,5 kW/24 V	●
Batteries 170 Ah/2 × 12 V	●
Cooling fan, hydrostatic driven	●
Fuel tank inlet strainer	●
Intake pipe with air pre-cleaner	○

TRANSMISSION AND BRAKES

Electronically controlled HST	●
Palm lever steering control (PCCS)	●
Quick shift selection system	●
Variable speed mode	●
Reverse speed presets	●
Combined decelerator/brake pedal	●

UNDERCARRIAGE

Komatsu PLUS link assembly	●
Single grouser heavy-duty shoes (EX: 600 mm; PX: 860 mm)	●
Segmented sprockets	●
Idler cushions	●
Track roller guard, centre and end section	●
Full length track roller guard	○

SERVICE AND MAINTENANCE

Swing-out hydrostat-driven radiator fan with reversing function	●
Dry type air cleaner, double element with dust indicator and evacuator	●
Water separator	●
Multi-function video compatible colour monitor with Equipment Management and Monitoring System (EMMS) and efficiency guidance	●
KOMTRAX™ - Komatsu wireless monitoring system	●
Komatsu CARE	●
Tool kit	●

CABIN

Air suspension seat: fabric, reclining, heated, high backrest	●
Seat belt with visible alert	●
High mount footrest	●
Air conditioner	●
Radio	●
Auxiliary input (MP3 jack)	●
2 × 12 Volt power supply (120 W)	●
1 × 24 Volt power supply	●
Viscous cab mounts	●
Rear-view mirror (inside cab)	●
Wiper front window	●
Wiper rear window	●
Wipers doors	●
Heated rear window	●
Cup holder	●
Lunch box holder	●

HYDRAULIC SYSTEM

Hydraulics for dozing blades	●
Mono lever blade control	●
Hydraulics for ripper	●

LIGHTING SYSTEM

Working lights, 3 cab roof front, 2 cab roof rear	●
---	---

SAFETY EQUIPMENT

Steel cab, meets ISO 3471 and SAE J1040, APR88 ROPS standards, as well as ISO 3449 FOPS standards	●
Horn	●
Locks, filter caps and covers	●
Back-up alarm	●
Rear view camera system	●
Fire extinguisher	○

ATTACHMENTS

Front pull hook	●
Hitch (not with ripper)	●
Rigid drawbar	○

DOZER EQUIPMENT

3,4 m³ PAT blade (EX)	○
3,8 m³ PAT blade (PX)	○
3,8 m³ PAT blade foldable (PX)	○
Multishank parallelogram ripper (EX only)	○

AUTOMATIC MACHINE CONTROL

Komatsu-Topcon Plug & Play provisions	●
Komatsu-Topcon machine control systems	○

Further equipment on request

- standard equipment
- optional equipment

Your Komatsu partner:

KOMATSU

**Komatsu Europe
International N.V.**
Mechelsesteenweg 586
B-1800 VILVOORDE (BELGIUM)
Tel. +32-2-255 24 11
Fax +32-2-252 19 81
www.komatsu.eu

EENSS20032 08/2016

Materials and specifications are subject to change without notice.
KOMATSU is a trademark of Komatsu Ltd. Japan.