

KOMATSU



PC
138US

Hydraulic Excavator

PC138US-8

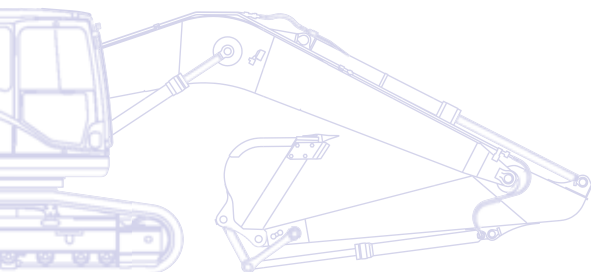

ENGINE POWER
72,0 kW / 96,6 HP @ 2.200 rpm

OPERATING WEIGHT
13.500 - 15.000 kg

BUCKET CAPACITY
max. 0,8 m³

Walk-Around

The Komatsu PC138US-8 hydraulic excavator was designed with an ultra-short tail swing to meet the challenges of work in confined areas. With a near-zero tail swing radius, it's the ultimate machine for jobsite safety and is perfect for work on roadways, bridges, in urban areas, or anywhere with limited work space. The PC138US-8 delivers the quality, performance and productivity you can expect from Komatsu equipment.

Powerful and environmentally friendly

- Low consumption ecot3 engine
- Komatsu integrated hydraulic system
- Eco-gauge and idle caution
- Reduced wastage

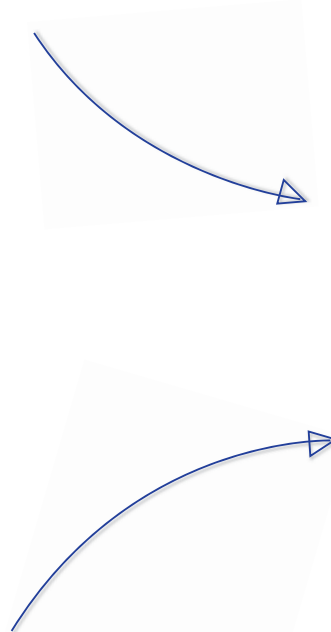

Quality you can rely on

- Reliable and efficient
- Rugged design
- Sliding door
- Komatsu-quality components
- Extensive dealer support network



PC138US-8

ENGINE POWER
72,0 kW / 96,6 HP @ 2.200 rpm

OPERATING WEIGHT
13.500 - 15.000 kg

BUCKET CAPACITY
max. 0,8 m³

First-class operator comfort

- Wide, spacious cab
- Low noise design
- Low vibration levels
- Pressurised cab
- Large, widescreen TFT monitor panel



Highest safety standards

- Safe SpaceCab™
- Rear view camera
- Optimal jobsite safety
- Safe access, easy maintenance
- Falling Object Protection System (FOPS) optional

Total versatility

- Ultra-short tail swing
- Ideal for a wide range of applications
- 5 working modes
- Wide choice of options
- Built-in versatility



KOMTRAX

Komatsu Satellite
Monitoring System

Total Versatility

Ideal for a wide range of applications

Powerful and precise, the Komatsu PC138US-8 is equipped to efficiently carry out any task your business requires. On big sites or small, for digging, trenching, landscaping or site preparation, the Komatsu original equipment hydraulic system always ensures maximum productivity and control.

5 working modes

Power, Lifting, Breaker, Attachment, and Economy.

The PC138US-8 features 5 selectable working modes that optimise performance and fuel usage. The Economy mode can be adjusted for an ideal balance between power and economy to match your work. The oil flow delivered to hydraulic attachments is adjustable directly on the class-leading wide screen monitor panel.

Built-in versatility

To allow the use of many attachments, such as buckets, breakers or demolition tools, a power supply for a hydraulic quick coupler with adjustable pressure settings, and an additional hydraulic circuit controlled by a foot pedal and a sliding joystick push button are standard on the PC138US-8. A second optional auxiliary line is also available for attachments that require extra hydraulic actuation.

Many options

With many options available – such as road-liner track shoes or a dozer blade – you can configure the PC138US-8 to match specific demands for transport, working envelope or duty. For maximum versatility you can choose between mono, two-piece or parallel offset boom. Extra hydraulic arrangements are available for every boom and arm configuration, making sure that the machine always contributes strongly to your business.



Additional hydraulic circuits (optional)



500 mm road-liner shoes (optional)





Short tail swing and exceptional stability

The PC138US-8 has a rounded profile with minimal protrusions at both the front and the rear. Its ultra-short tail swing radius is perfect for work in tight spaces, particularly in urban areas, or for road construction, logging and demolition. Thanks to optimised packaging, the PC138US-8 is exceptionally stable. Coupled with the machine's wide working range, this stability makes it ideal for any work requiring long reach, such as demolition jobs and slope cutting. With ample dumping reach available for loading operations, the operator can always work easily, efficiently and with absolute confidence.

Powerful and Environmentally Friendly

Low consumption ecot3 engine

The Komatsu SAA4D95LE-5 engine provides high torque, a better performance at low speed and low fuel consumption. This ecot3 engine features a new combustion chamber design with optimised ignition and combustion timing. The operating pressure of the new common rail system was increased for improved injection and fuel efficiency. The air-to-air charge cooler reduces the temperature of the compressed air supplied by the turbo charger to the cylinders, and further improves fuel consumption.

Meets EU Stage IIIA

The new Komatsu ecot3 engine technology reduces NOx and particle emissions, fuel consumption and noise level. The Komatsu SAA4D95LE-5 engine is certified for EPA Tier III and EU Stage IIIA emission regulations. To further reduce the machine's emissions, a Diesel Particulate Filter is also available.

Komatsu integrated hydraulic system

The PC138US-8 is a highly responsive and productive machine with all major hydraulic parts designed and manufactured by Komatsu. The electronic Closed Load Sensing hydraulic System (CLSS) offers complete control during individual or combined movements - without sacrificing performance or productivity.

Eco-gauge and idle caution

The unique ECO-gauge helps the operator reduce emissions and fuel consumption for environmentally friendly and energy saving operations. And to further avoid wasting fuel when the machine is not actually working, a standard-fit idle caution is displayed if the engine idles for 5 minutes or more.

Komatsu SAA4D95LE-5



Eco-gauge



Idle caution





Reduced wastage

To avoid spillage of excess grease – and prolong the life of your machine – the PC138US-8 can be equipped with an automatic greasing system that provides precisely the correct amount of grease when and where it's required.



First-Class Operator Comfort

Wide spacious cab

The newly designed, wide and spacious cab includes a comfortable air suspension seat with a reclining backrest. The seat height and longitudinal inclination are easily adjusted with a pull-up lever. You can also set the operational posture of the armrest and the position of the console or recline the seat all the way and place it into a fully flat state with the headrest attached.

Pressurised cab

An automatic air conditioner, an air filter and a positive internal air pressure (60 Pa) combine to prevent external dust from entering the cab.

Low noise design

Komatsu Dash 8 crawler excavators feature the lowest in-class external noise levels and are especially well-suited for work in confined spaces or urban areas. Reduced fan speed, a large capacity radiator, and the optimal usage of sound insulation and of sound absorbing materials help to make noise levels inside Dash 8 excavators comparable to those inside an executive car.

Cab damper mounting

The built-in stability of the Komatsu PC138US-8, combined with a highly rigid deck and a sprung multi-layer viscous mount system, drastically reduces vibration levels for the operator.



Automatic air conditioner



Quick-coupler piping standard



Joysticks with proportional control button for attachments





Large, widescreen TFT monitor

To enable safe, accurate and smooth work, the user friendly monitor is the highly intuitive user interface for the machine's Equipment Management and Monitoring System (EMMS). Multilingual and with all essential information available at a glance, it features simple and easy to operate switches and multifunction keys that provide the operator with fingertip access to a wide range of functions and operating information.





Highest Safety Standards

Safe operation in confined areas

The machine's rounded profile allows it to operate in narrow spaces or where there are a number of obstructions. The compact tail design minimises the risks of rear impact and lets the operator concentrate fully on his work.

Optimal job site safety

Safety features on the Komatsu PC138US-8 comply with the latest industry standards and work together as a system to minimise risks to personnel in and around the machine. An audible travel alarm further promotes job site safety. Very durable anti-slip plates – with additional high friction covering – maintain long term traction performance.

Safe SpaceCab™

Specifically designed for Komatsu excavators, the Dash 8 cab has a tubular steel frame. It provides very high shock absorbency, impact resistance and durability. The seat belt is designed to keep the operator in the safety zone of the cab in the event of a roll-over. At your request, the Komatsu PC138US-8 can also be fitted with an ISO 10262 Level 2 Falling Object Protective System (FOPS).

Rear view camera

A standard fitment camera gives an exceptionally clear view of the rear work zone on the wide-screen monitor panel. Large mirrors on both sides ensure that machine visibility meets the latest ISO standards.

Short tail swing radius:

1,48 m – Because the tail of the PC138US-8 is more compact than conventional models, the PC138US-8 reduces the operator's need to check behind him for movement.

Short implement swing radius:

1,98 m – Boom raising angle of the PC138US-8 is larger than the PC130-8, while front implement protrusion is lessened.



Rear view camera



Safe SpaceCab™



Anti-slip plates



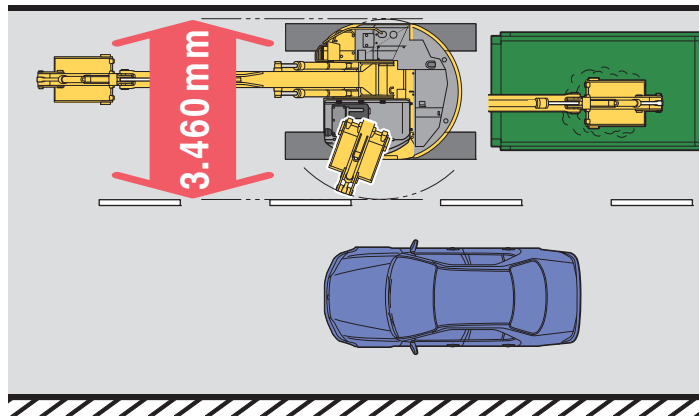
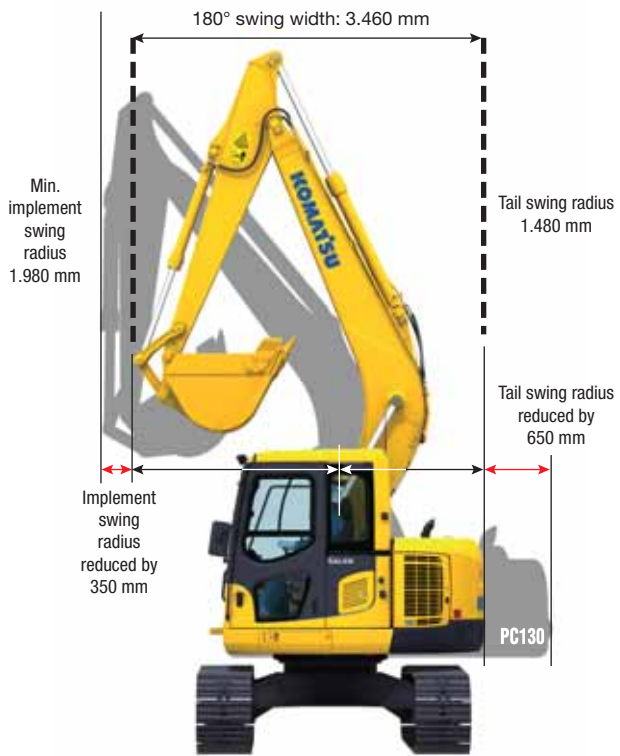

When performing road work, protrusion of the machine into the unoccupied lane is kept to a minimum. This allows a dump truck to be positioned closer to the track of the machine.



Quality You Can Rely On

Reliable and efficient

Productivity is the key to success – all major components of the PC138US-8 are designed and directly manufactured by Komatsu. Essential machine functions are perfectly matched for a highly reliable and productive machine.

Rugged design

Maximum toughness and durability – along with top class customer service – are the cornerstones of Komatsu's philosophy. Single piece plates and castings are used in key areas of the machine's structure for good load distribution.

Komatsu-quality components

With the latest computer design techniques and a thorough test programme, Komatsu's global know-how produces machines that are designed, manufactured and tested to meet your highest standards.

Extensive dealer support network

The extensive Komatsu distribution and dealer network is standing by to help keep your fleet in optimum condition. Customised servicing packages are available, with express availability of spare parts, to make sure that your Komatsu will continue to perform at its peak.



Cast boom foot



The sliding door facilitates easy entrance in confined areas while reducing the risk of damage on roadways. The cab also features a sliding window.



Komatsu Satellite Monitoring System



KOMTRAX™ is a revolutionary machine tracking system designed to save you time and money. You can now monitor your equipment anytime and anywhere. Use valuable machine data received via the KOMTRAX™ web site to optimise your maintenance planning and machine performances.

KOMTRAX™ can assist you with:

Full machine monitoring

Get detailed operation data to know when your machines are used and how productive they are.

Total Fleet Management

Keep track of the location of your machines at all times and discourage unapproved usage or theft.

Complete machine status

Receive warnings, alerts and cautions, via a web site or by e-mail, to help with maintenance planning and for longer machine life.

For further details on KOMTRAX™, please ask your Komatsu dealer for the latest KOMTRAX™ brochure.





Machine working time - With the "daily working record" chart, get precise engine running time data: when your machine was started and when it was shut down, as well as total engine running time.



Maintenance planning - To increase productivity and improve maintenance planning, alerts indicate when items such as filters or oil must be replaced.



Fleet location - The machine list instantly locates all your machines, even those in other countries.



Machine tracking during transport - When your machine is transported, KOMTRAX™ sends travel messages to the web site or by e-mail to inform you of its progress, and confirms when it reaches its destination.



Alarm notifications - You can receive notification of alarms both via the KOMTRAX™ website and by e-mail.



Added security - The "engine lock" feature allows to program when a machine's engine can be started. And with "geo-fence", KOMTRAX™ sends notification every time your machine moves in or out of a predetermined operating area.



Easy Maintenance

Optimum maintenance layout

Effortless access to engine-related maintenance items such as oil filter, oil dipstick, coolant reserve tank, fuel filter, and air cleaner.

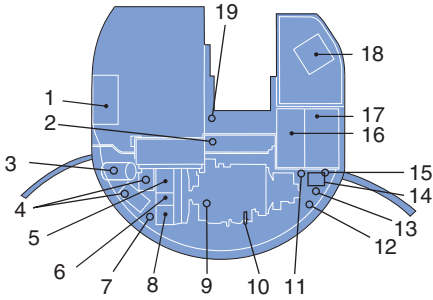

1. Tool box
2. Swing machinery oil filler
3. Air cleaner
4. Batteries
5. Oil cooler
6. Aftercooler
7. Windshield washer tank
8. Radiator
9. Engine oil filler
10. Engine oil dipstick
11. Engine oil filter
12. PTO oil filler
13. Fuel drain valve
14. Coolant reserve tank
15. Fuel filter (with water separator)
16. Hydraulic tank
17. Fuel tank
18. Control valve
19. Swing machinery dipstick

Water separator

This is standard equipment which removes any water that has become mixed with the fuel, preventing fuel system damage.



A large tool box provides plenty of space and room for the hose of the refuelling pump.

Washable floor

The PC138US-8's floor is easy to keep clean. The gently inclined surface has a flanged floormat and drainage holes to facilitate runoff.

Long-life oil filters

The hydraulic oil filter uses high-performance filtering material for long element replacement intervals, which significantly reduces maintenance costs.



Side-by-side cooling

Since the radiator, aftercooler and oil cooler are arranged in parallel, it is easy to clean, remove and install them.

Long greasing interval

Special hard material is used for the bushings of the work equipment to lengthen greasing interval. All bushing lubrication intervals of work equipment except arm top bushing are 500 hours, reducing maintenance costs.

Flexible warranty

When you purchase Komatsu equipment, you gain access to a broad range of programmes and services that have been designed to help you get the most from your investment. For example, Komatsu's Flexible Warranty Programme provides a range of extended warranty options on the machine and its components. These can be chosen to meet your individual needs and activities. This programme is designed to help reduce total operating costs.



ENGINE

Model	Komatsu SAA4D95LE-5
Type	Common rail direct injection, water-cooled, emissionised, turbocharged, after-cooled diesel
Engine power	
at rated engine speed	2.200 rpm
ISO 14396	72,0 kW / 96,6 HP
ISO 9249 (net engine power)	68,0 kW / 91,2 HP
No. of cylinders	4
Bore x stroke	95 x 115 mm
Displacement	3,26 ltr
Starter motor	4,5 kW
Alternator	24 V/60 A
Battery	2 x 12 V/72 Ah
Air filter type	Double element type with monitor panel dust indicator and auto dust evacuator

HYDRAULIC SYSTEM

Type	HydrauMind. Closed-centre system with load sensing and pressure compensation valves
Main pump	Variable-capacity piston pump
Pumps for	Boom, arm, bucket, swing, and travel circuits
Maximum pump flow	242 ltr/min
Hydraulic motors:	
Travel	2 x axial piston motor with parking brake
Swing	1 x axial piston motor with swing holding brake
Relief valve settings:	
Implement	355 bar
Travel	355 bar
Swing	276 bar
Pilot	33 bar

DRIVES AND BRAKES

Steering control	2 levers with pedals giving full independent control of each track
Drive method	Hydrostatic
Max. drawbar pull	12.500 kgf
Max. travel speeds	
Lo / Hi	2,9 / 5,1 km/h

SWING SYSTEM

Type	Axial piston motor driving through planetary double reduction gearbox
Swing lock	Electrically actuated wet multi-disc brake integrated into swing motor
Swing speed	0 - 11 rpm
Swing torque	3.357 kgm

UNDERCARRIAGE

Construction	X-frame centre section with box section track-frames
Track assembly	
Type	Fully sealed
Shoes (each side)	43
Tension	Combined spring and hydraulic unit
Rollers	
Track rollers (each side)	7
Carrier rollers (each side)	1

SERVICE REFILL CAPACITIES

Fuel tank	195 ltr
Radiator	12,4 ltr
Engine	11 ltr
Final drive (each side)	2,5 ltr
Swing drive	2,5 ltr
Hydraulic tank	69 ltr

ENVIRONMENT

Engine emissions	Fully complies with EU Stage IIIA and EPA Tier III exhaust emission regulations
Noise levels	
LwA external	100 dB(A) (2000/14/EC Stage II)
LpA operator ear	72 dB(A) (ISO 6396 dynamic test)
Vibration levels (EN 12096:1997)*	
Hand/arm	≤ 2,5 m/s ² (uncertainty K = 0,38 m/s ²)
Body	≤ 0,5 m/s ² (uncertainty K = 0,07 m/s ²)

* for the purpose of risk assessment under directive 2002/44/EC, please refer to ISO/TR 25398:2006.

Specifications

OPERATING WEIGHT (APPR.)

Triple grouser shoes	MONO BOOM		TWO-PIECE BOOM		OFFSET BOOM	
	Operating weight	Ground pressure	Operating weight	Ground pressure	Operating weight	Ground pressure
500 mm	13.480 kg	0,43 kg/cm ²	14.300 kg	0,46 kg/cm ²	13.540 kg	0,43 kg/cm ²
600 mm	13.670 kg	0,36 kg/cm ²	14.490 kg	0,38 kg/cm ²	13.730 kg	0,36 kg/cm ²
700 mm	13.850 kg	0,31 kg/cm ²	14.670 kg	0,33 kg/cm ²	13.910 kg	0,31 kg/cm ²

Operating weight including specified work equipment, 2.500 mm arm (offset boom: 2.100 mm arm), 470 kg backhoe bucket, rated capacity of lubricants, coolant, full fuel tank and standard equipment.

Additional weight with blade: + 900 kg
 Additional weight with 500 mm road-liner: + 130 kg
 Additional counterweight: + 500 kg

MAX. BUCKET CAPACITY AND WEIGHT

Arm length	MONO BOOM					
	2,1 m		2,5 m		3,0 m	
Material weight up to 1,2 t/m ³	0,8 m ³	620 kg	0,72 m ³	560 kg	0,72 m ³	560 kg
Material weight up to 1,5 t/m ³	0,72 m ³	560 kg	0,64 m ³	505 kg	0,64 m ³	505 kg
Material weight up to 1,8 t/m ³	0,64 m ³	505 kg	0,56 m ³	475 kg	0,48 m ³	470 kg

Arm length	TWO-PIECE BOOM					
	2,1 m		2,5 m		3,0 m	
Material weight up to 1,2 t/m ³	0,8 m ³	620 kg	0,72 m ³	560 kg	0,72 m ³	560 kg
Material weight up to 1,5 t/m ³	0,72 m ³	560 kg	0,64 m ³	505 kg	0,64 m ³	505 kg
Material weight up to 1,8 t/m ³	0,64 m ³	505 kg	0,56 m ³	475 kg	0,48 m ³	470 kg

Max. capacity and weight have been calculated according to ISO 10567:2007.

Please consult with your distributor for the correct selection of buckets and attachments to suit the application.

A full range of Komatsu wear parts is available.

A wide range of attachments is available. Please consult your distributor for details of the full range.





MACHINE DIMENSIONS

MONO BOOM

E	Overall height of cab	2.815 mm
F	Clearance under counterweight	900 mm
G	Ground clearance	395 mm
H	Tail swing radius	1.480 mm
I	Length of track on ground	2.880 mm
J	Track length	3.610 mm
K	Track gauge	1.990 mm
L	Overall track width with 500 mm shoe	2.490 mm
	Overall track width with 600 mm shoe	2.590 mm
	Overall track width with 700 mm shoe	2.690 mm
M	Shoe width	500, 600, 700 mm
N	Grouser height	20 mm
O	Machine tail height	1.980 mm
P	Overall width of upper structure	2.490 mm
Q	Distance, swing center to rear end (with add. counterweight)	1.545 mm
R	Distance, swing center to blade	2.490 mm
S	Blade, max. lifting height	470 mm
T	Height of blade	590 mm
U	Blade, max. digging depth	525 mm
	Blade width (with 500 mm shoes)	2.490 mm
	Blade width (with 600 mm shoes)	2.590 mm

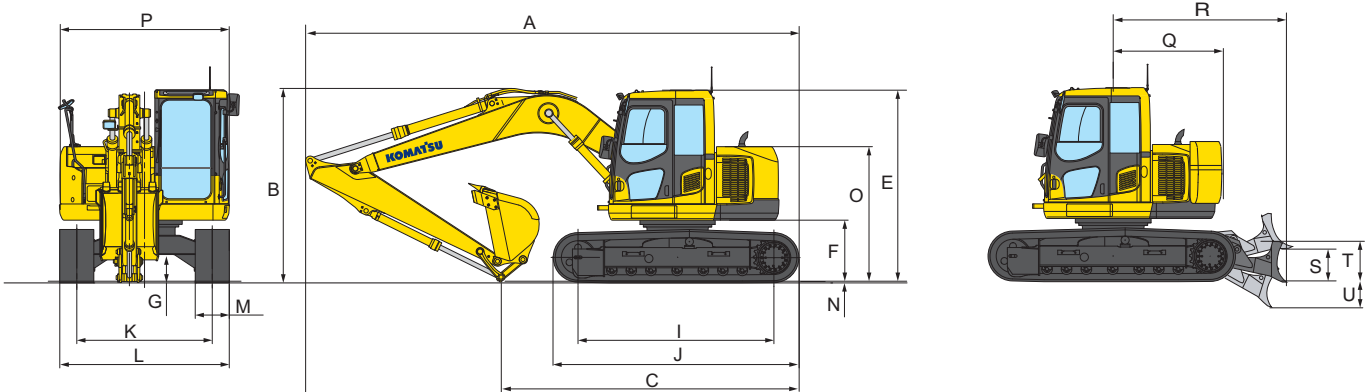
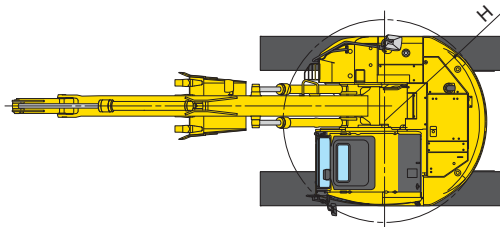

MONO BOOM

	Arm length	2.100 mm	2.500 mm	3.000 mm
A	Transport length	7.275 mm	7.260 mm	7.160 mm
B	Overall height (to top of boom)	2.690 mm	2.850 mm	3.210 mm
C	Length on ground (transport)	4.660 mm	4.400 mm	4.290 mm

Dimensions

MACHINE DIMENSIONS		TWO-PIECE BOOM
E	Overall height of cab	2.815 mm
F	Clearance under counterweight	900 mm
G	Ground clearance	395 mm
(H)	Tail swing radius	1.545 mm
I	Length of track on ground	2.880 mm
J	Track length	3.610 mm
K	Track gauge	1.990 mm
L	Overall track width with 500 mm shoe	2.490 mm
	Overall track width with 600 mm shoe	2.590 mm
	Overall track width with 700 mm shoe	2.690 mm
M	Shoe width	500, 600, 700 mm
N	Grouser height	20 mm
O	Machine tail height	2.075 mm
P	Overall width of upper structure	2.490 mm
Q	Distance, swing center to rear end (with add. counterweight)	1.545 mm
R	Distance, swing center to blade	2.490 mm
S	Blade, max. lifting height	470 mm
T	Height of blade	590 mm
U	Blade, max. digging depth	525 mm
	Blade width (with 500 mm shoes)	2.490 mm
	Blade width (with 600 mm shoes)	2.590 mm

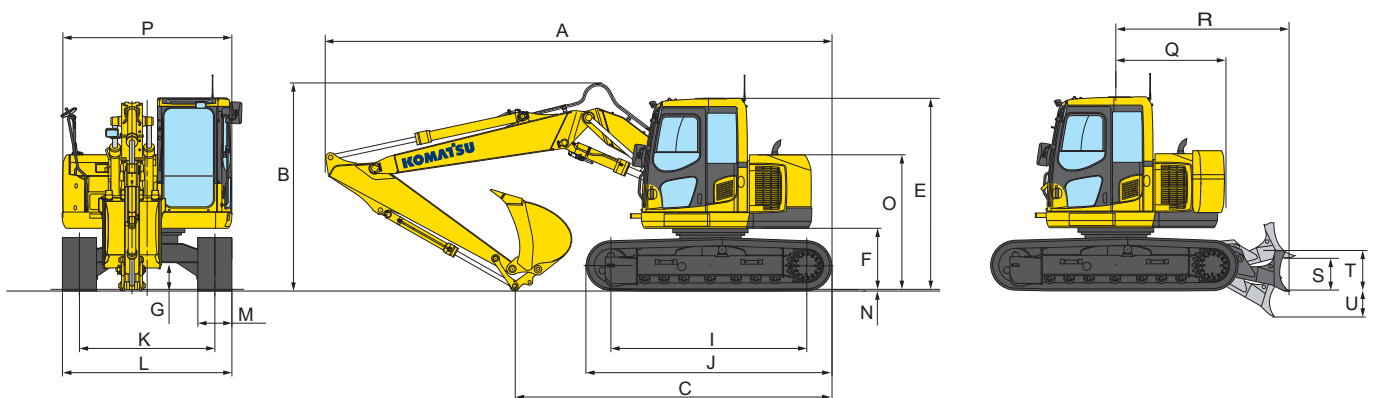

TWO-PIECE BOOM

	Arm length	2.100 mm	2.500 mm
A	Transport length	7.460 mm	7.450 mm
B	Overall height (to top of hose)	2.930 mm	3.050 mm
C	Length on ground (transport)	4.935 mm	4.670 mm



MACHINE DIMENSIONS

OFFSET BOOM

MACHINE DIMENSIONS	OFFSET BOOM
E Overall height of cab	2.815 mm
F Clearance under counterweight	900 mm
G Ground clearance	395 mm
H Tail swing radius	1.480 mm
I Length of track on ground	2.880 mm
J Track length	3.610 mm
K Track gauge	1.990 mm
L Overall track width with 500 mm shoe	2.490 mm
Overall track width with 600 mm shoe	2.590 mm
Overall track width with 700 mm shoe	2.690 mm
M Shoe width	500, 600, 700 mm
N Grouser height	20 mm
O Machine tail height	1.980 mm
P Overall width of upper structure	2.490 mm
(Q) Distance, swing center to rear end (with add. counterweight)	1.545 mm
R Boom offset, right hand	1.150 mm
S Boom offset, left hand	1.170 mm

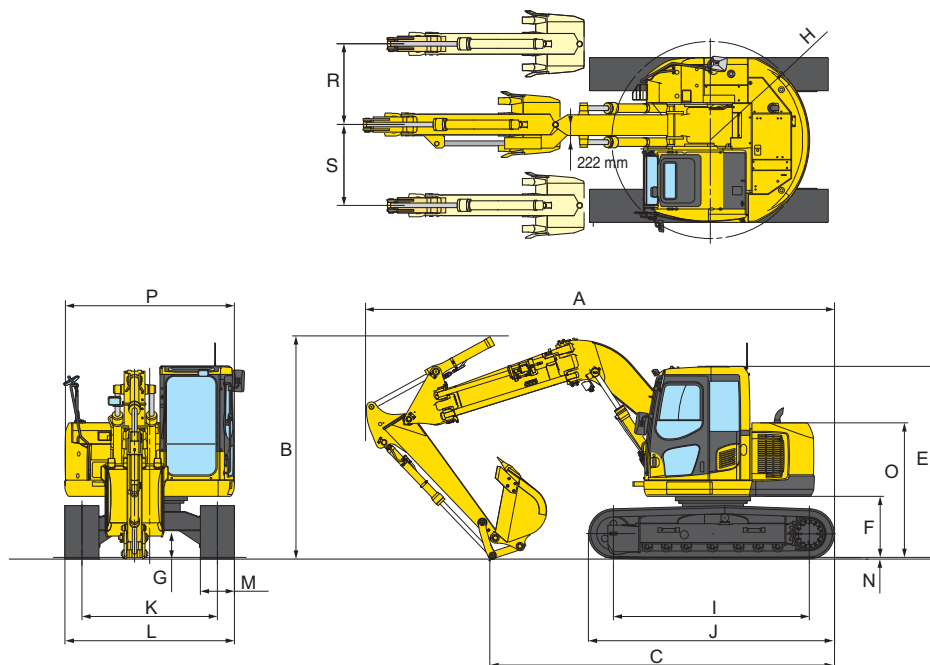

OFFSET BOOM

Arm length	2.100 mm
A Transport length	6.800 mm
B Overall height (to top of cylinder)	3.245 mm
C Length on ground (transport)	5.010 mm

Working Range

MONO BOOM

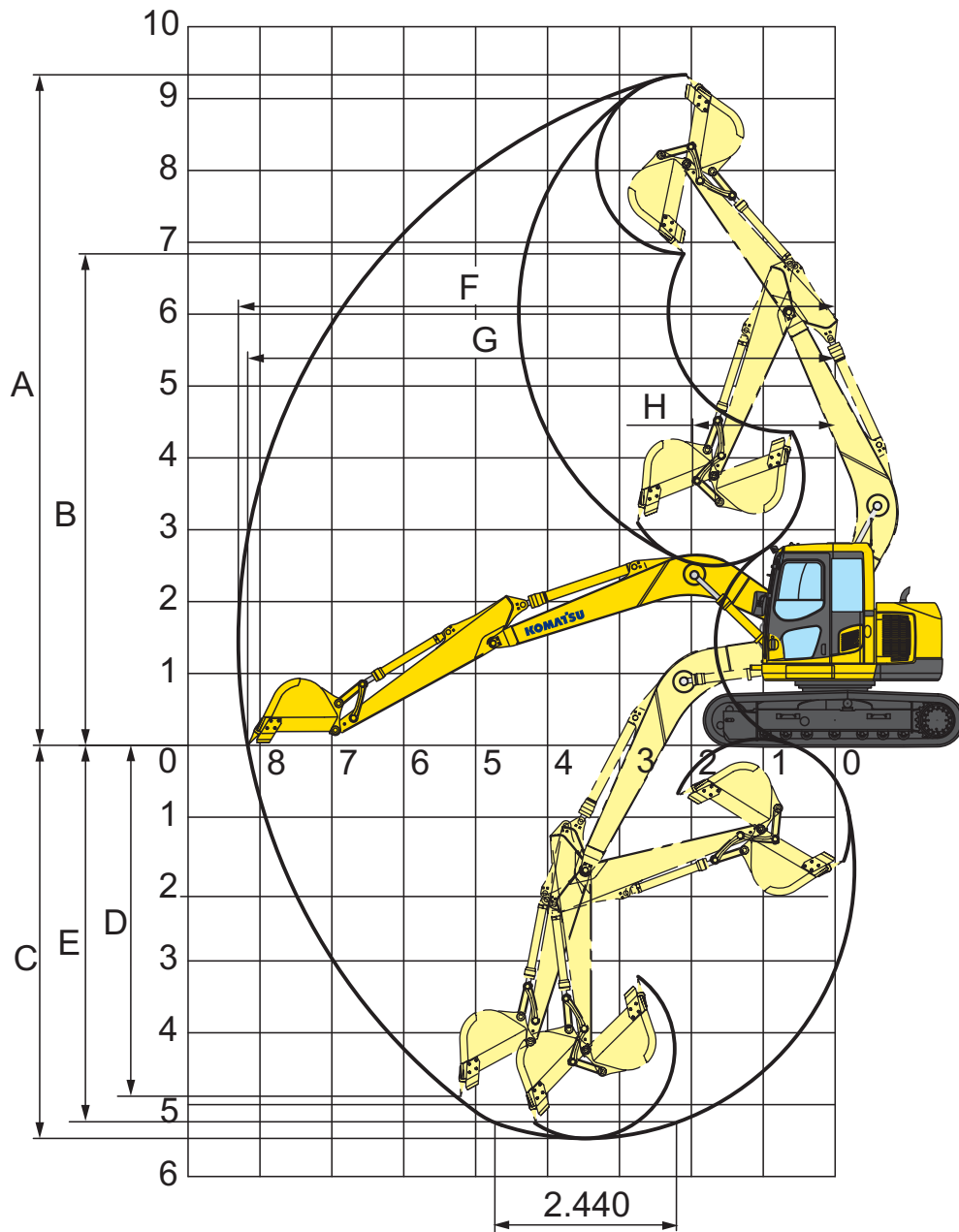

ARM LENGTH	2.100 mm	2.500 mm	3.000 mm
A Max. digging height	9.020 mm	9.340 mm	9.700 mm
B Max. dumping height	6.525 mm	6.840 mm	7.350 mm
C Max. digging depth	5.070 mm	5.480 mm	5.900 mm
D Max. vertical wall digging depth	4.490 mm	4.900 mm	5.340 mm
E Max. digging depth of cut for 2,44 m level	4.830 mm	5.265 mm	5.715 mm
F Max. digging reach	7.930 mm	8.300 mm	8.720 mm
G Max. digging reach at ground level	7.805 mm	8.180 mm	8.600 mm
H Min. swing radius	1.845 mm	1.980 mm	2.265 mm
Bucket digging force (ISO)	9.000 kgf	9.500 kgf	9.000 kgf
Arm crowd force (ISO)	7.300 kgf	6.300 kgf	5.700 kgf

TWO-PIECE BOOM

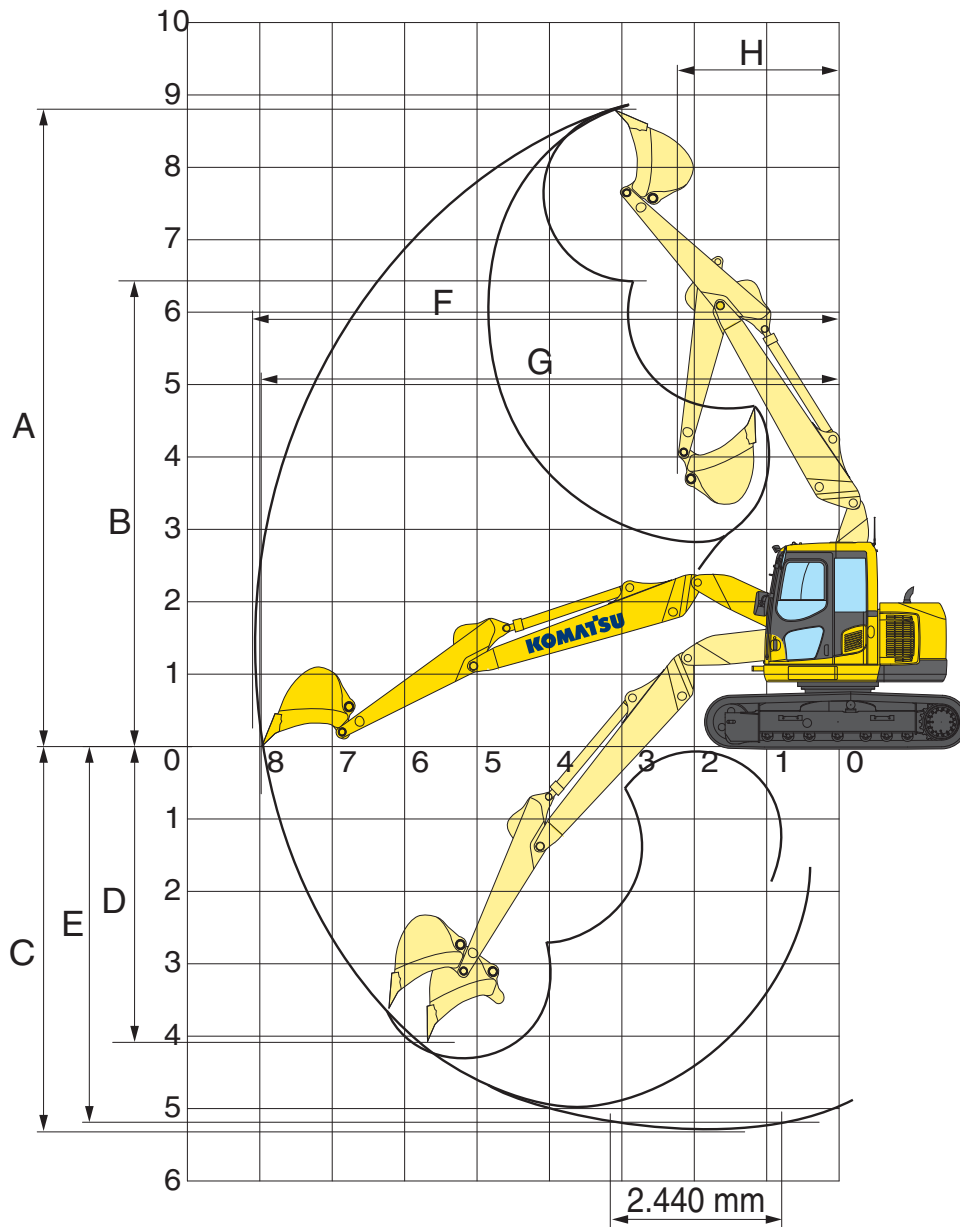

ARM LENGTH	2.100 mm	2.500 mm
A Max. digging height	8.845 mm	9.130 mm
B Max. dumping height	6.465 mm	6.750 mm
C Max. digging depth	5.280 mm	5.680 mm
D Max. vertical wall digging depth	3.830 mm	4.400 mm
E Max. digging depth of cut for 2,44 m level	5.165 mm	5.570 mm
F Max. digging reach	8.135 mm	8.510 mm
G Max. digging reach at ground level	8.000 mm	8.380 mm
H Min. swing radius	2.430 mm	2.500 mm

Working Range

OFFSET BOOM

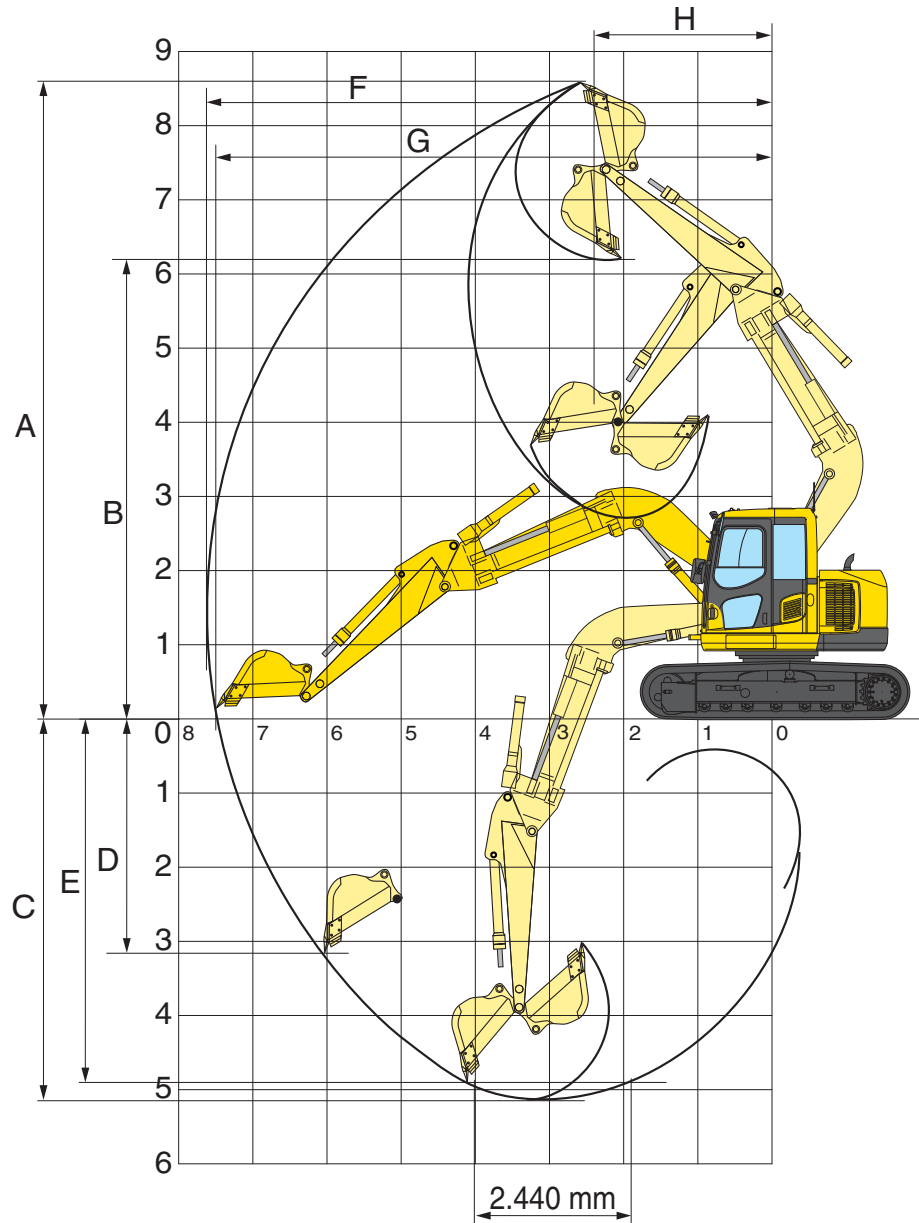

ARM LENGTH	2.100 mm
A Max. digging height	8.200 mm
B Max. dumping height	5.900 mm
C Max. digging depth	4.820 mm
D Max. vertical wall digging depth	2.965 mm
E Max. digging depth of cut for 2,44 m level	4.445 mm
F Max. digging reach	7.285 mm
G Max. digging reach at ground level	7.135 mm
H Min. swing radius	2.220 mm

MONO BOOM

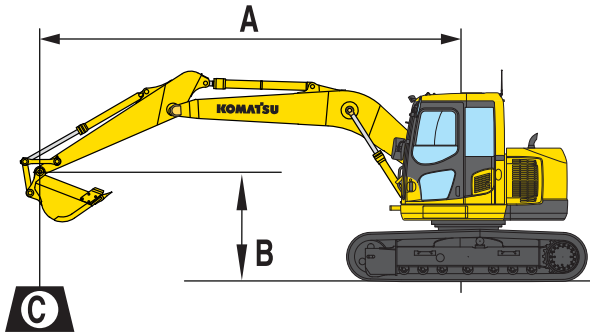

A – Reach from swing center

B – Bucket hook height

C – Lifting capacities, including bucket (450 kg), bucket linkage and bucket cylinder

When removing bucket, linkage or cylinder, lifting capacities can be increased by their respective weights

With 500 mm shoes

– Rating over front

– Rating over side

– Rating at maximum reach

Arm length	A				7,0 m		6,0 m		4,5 m		3,0 m		1,5 m	
	B													
 3.000 mm 450 kg 0,5 m ³	6,0 m	kg	*1.620	*1.620					*2.810	*2.810				
	4,5 m	kg	*1.510	1.480			*2.880	1.930	*3.040	*3.040				
	3,0 m	kg	*1.530	1.260	2.240	1.380	2.960	1.870	*3.730	3.090	*4.970	*4.970		
	1,5 m	kg	*1.630	1.170	2.190	1.330	2.850	1.770	*4.600	2.850	*7.270	5.430		
	0,0 m	kg	*1.860	1.180	2.130	1.280	2.750	1.680	4.380	2.650	*7.350	4.990		
	-1,5 m	kg	2.190	1.310			2.690	1.620	4.270	2.550	*8.020	4.870	*4.070	*4.070
	-3,0 m	kg	2.740	1.660					4.270	2.550	*6.770	4.920	*6.870	*6.870
-4,5 m	kg	*2.500	*2.500							*4.180	*4.180			
 2.500 mm 450 kg 0,5 m ³	6,0 m	kg	*2.060	*2.060					*3.270	3.220				
	4,5 m	kg	*1.920	1.730			*2.890	1.890	*3.460	3.200	*3.960	*3.960		
	3,0 m	kg	*1.950	1.450			2.940	1.860	*4.140	3.050	*5.870	*5.870		
	1,5 m	kg	*2.120	1.350			2.850	1.780	4.590	2.840	*7.960	5.330		
	0,0 m	kg	2.250	1.370			2.780	1.710	4.300	2.580	*6.750	5.030		
	-1,5 m	kg	2.540	1.550			2.740	1.680	4.340	2.620	*7.740	4.990	*4.710	*4.710
	-3,0 m	kg	*3.130	2.060					*4.160	2.650	*6.140	5.090	*8.310	*8.310
-4,5 m	kg													
 2.100 mm 450 kg 0,5 m ³	6,0 m	kg	*2.620	*2.620					*3.530	3.150	*3.860	*3.860		
	4,5 m	kg	*2.420	1.950					*3.780	3.150	*4.560	*4.560		
	3,0 m	kg	*2.460	1.610			2.910	1.830	*4.420	3.000	*6.530	5.820		
	1,5 m	kg	2.410	1.490			2.840	1.770	4.550	2.810				
	0,0 m	kg	2.480	1.520			2.780	1.710	4.260	2.560	*6.240	5.000		
	-1,5 m	kg	2.850	1.750					4.230	2.530	*7.300	5.020	*5.280	*5.280
	-3,0 m	kg	*3.190	2.430					*3.660	2.700	*5.440	5.150		
-4,5 m	kg													

* Load is limited by hydraulic capacity rather than tipping.

Ratings are based on SAE Standard No. J1097.

Rated loads do not exceed 87% of hydraulic lift capacity or 75% of tipping load.

Lifting Capacity

TWO-PIECE BOOM

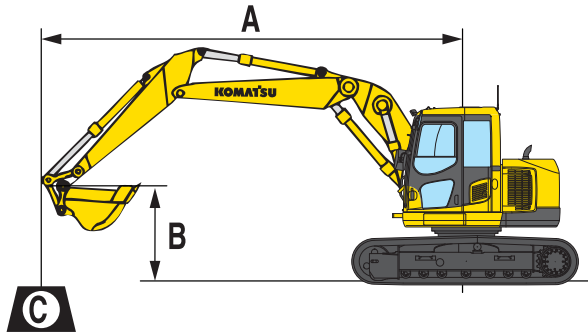

- A** – Reach from swing center
- B** – Bucket hook height
- C** – Lifting capacities, including bucket (450 kg), bucket linkage and bucket cylinder

When removing bucket, linkage or cylinder, lifting capacities can be increased by their respective weights

With 500 mm shoes

- Rating over front
- Rating over side
- Rating at maximum reach

Arm length	A				7,5 m		6,0 m		4,5 m		3,0 m		1,5 m	
	B	kg												
 2.500 mm 450 kg 0,5 m³	7,5 m	kg	*2.500	*2.500										
	6,0 m	kg	*2.050	*2.050					*3.100	*3.100				
	4,5 m	kg	*1.900	1.550			2.750	2.050	*3.350	*3.350				
	3,0 m	kg	1.800	1.300			2.700	1.950	*4.100	3.250	*5.850	*5.850		
	1,5 m	kg	1.700	1.200	1.700	1.200	2.550	1.850	4.200	3.000				
	0,0 m	kg	1.700	1.200	1.700	1.200	2.450	1.750	4.000	2.800				
	-1,5 m	kg	1.900	1.350			2.400	1.700	3.900	2.700	*7.500	4.600		
	-3,0 m	kg	2.400	1.700			2.450	1.700	3.900	2.700	*7.450	5.300		
	-4,5 m	kg												
 2.100 mm 450 kg 0,5 m³	7,5 m	kg	*3.200	*3.200										
	6,0 m	kg	*2.500	2.350					*3.500	*3.500				
	4,5 m	kg	*2.350	1.700			2.700	2.000	*3.700	3.450				
	3,0 m	kg	2.000	1.450			2.650	1.950	4.350	3.200	*6.550	6.300		
	1,5 m	kg	1.850	1.350			2.550	1.850	4.150	2.950				
	0,0 m	kg	1.900	1.350			2.450	1.750	3.950	2.750				
	-1,5 m	kg	2.150	1.500			2.450	1.750	3.900	2.700	*7.750	4.650		
	-3,0 m	kg	2.800	2.000					3.950	2.750	*6.850	5.400		
	-4,5 m	kg												

* Load is limited by hydraulic capacity rather than tipping.
 Ratings are based on SAE Standard No. J1097.
 Rated loads do not exceed 87% of hydraulic lift capacity or 75% of tipping load.

OFFSET BOOM

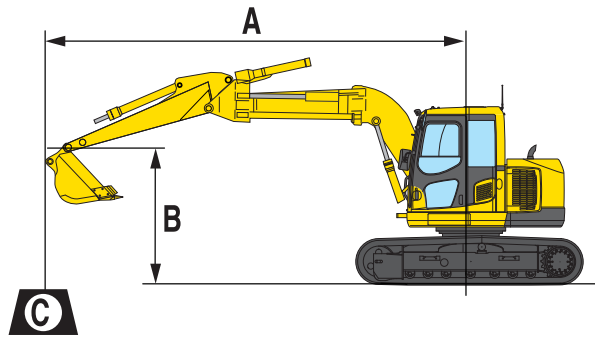













- A** – Reach from swing center
- B** – Bucket hook height
- C** – Lifting capacities, including bucket (450 kg), bucket linkage and bucket cylinder

When removing bucket, linkage or cylinder, lifting capacities can be increased by their respective weights

With 500 mm shoes

-  – Rating over front
-  – Rating over side
-  – Rating at maximum reach

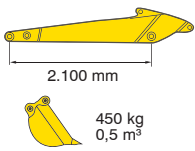
Arm length	A				7,0 m		6,0 m		4,5 m		3,0 m		1,5 m	
	B													
	6,0 m	kg	*2.140	*2.140							*3.130	*3.130		
	4,5 m	kg	*2.060	*2.060			*2.210	1.810	*3.210	*3.210	*3.160	*3.160		
	3,0 m	kg	*2.190	1.750			*2.890	1.790	*3.780	3.030	*5.070	*5.070		
	1,5 m	kg	*2.530	1.540			2.770	1.670	4.520	2.740				
	0,0 m	kg	2.590	1.530			2.650	1.570	4.250	2.500				
	-1,5 m	kg	2.990	1.750					4.130	2.390	*7.590	4.600		
	-3,0 m	kg	*4.090	2.560					*3.780	2.450	*6.120	4.740	*8.020	*8.020
-4,5 m	kg													

* Load is limited by hydraulic capacity rather than tipping.
 Ratings are based on SAE Standard No. J1097.
 Rated loads do not exceed 87% of hydraulic lift capacity or 75% of tipping load.

Hydraulic Excavator

PC138US-8

Standard and Optional Equipment

ENGINE

Komatsu SAA4D95LE-5, 72 kW turbocharged common rail direct injection diesel engine, EU Stage IIIA compliant	●
Suction type cooling fan with radiator fly screen	●
Automatic engine warm-up system	●
Engine overheat prevention system	●
Fuel control dial	●
Auto-deceleration function	●
Engine key stop	●
Engine ignition can be password secured on request	●
Alternator 24 V/60 A	●
Starter motor 24 V/4,5 kW	●
Batteries 2 × 12 V/72 Ah	●
Diesel particulate filter	○

HYDRAULIC SYSTEM

Electronic closed-centre load sensing (E-CLSS) hydraulic system (HydraMind)	●
Pump and engine mutual control (PEMC) system	●
5-working mode selection system; Power mode, economy mode, breaker mode, attachment mode and lifting mode	●
One additional 2-way full-flow service spool with attachment lines on boom and arm and pedal in cab (HCU A)	●
Adjustable PPC wrist control levers for arm, boom, bucket and swing, with sliding proportional control for attachments and 3 auxiliary buttons	●
Quick-coupler piping	●
Additional hydraulic circuit	○

UNDERCARRIAGE

Track frame under-guards	●
500 mm triple grouser shoes	●
600, 700 mm triple grouser shoes	○
500 mm road-liner (rubber) shoes	○

CABIN

Reinforced safety SpaceCab™; Highly pressurised and tightly sealed hyper viscous mounted cab with tinted safety glass windows, large roof hatch, pull-up type front window with locking device, removable lower window, front window wiper with intermittent feature, cigarette lighter, ashtray, luggage shelf, floor mat	●
Suspension seat with lumbar support, height adjustable arm rests and retractable seat belt	●
Automatic climate control system	●
12 Volt power supply	●
Beverage holder	●
Radio	●
Heated air suspension seat	○
Lower wiper	○

SERVICE AND MAINTENANCE

Automatic fuel line de-aeration	●
Double element type air cleaner with dust indicator and auto dust evacuator	●
KOMTRAX™ - Komatsu satellite monitoring system	●
Multi-function video compatible colour monitor with Equipment Management and Monitoring System (EMMS) and efficiency guidance	●
Toolkit and spare parts for first service	●

WORK EQUIPMENT

3,0 m arm, HCU assembly includes piping for one additional function	●
Mono boom	○
Two-piece boom	○
Offset boom	○
2,1 m; 2,5 m; 3,0 m arms (HCU assembly includes piping for one additional function)	○
Dozer blade (with 500 or 600 mm shoes)	○
Komatsu buckets	○
Komatsu breakers	○

SAFETY EQUIPMENT

Rear view camera system	●
Electric horn	●
Overload warning device	●
Lockable fuel cap and covers	●
Audible travel alarm	●
Boom safety valves	●
Large handrails, rear-view mirrors	●
Battery main switch	●
Arm safety valve	●
OPG Level II front guard (FOPS)	○
OPG Level II top guard (FOPS)	○

DRIVES AND BRAKES

Hydrostatic, 3-speed travel system with automatic shift and planetary gear type final drives, and hydraulic travel and parking brakes	●
PPC control levers and pedals for steering and travel	●

LIGHTING SYSTEM

Working lights: 1 revolving frame and 1 boom (r.h.)	●
Additional working lights: 5 cab roof, 1 boom (l.h.), 1 counterweight (rear), additional revolving frame (l.h.), beacon and harness for 2 lamps (not included) in boom foot area	○

OTHER EQUIPMENT

Remote greasing for swing circle and pins	●
Electric refuelling pump with automatic shut off function	●
Standard colour scheme and decals	●
Parts book and operator manual	●
Additional counterweight 500 kg	○

Further equipment on request

- standard equipment
- optional equipment

Your Komatsu partner:

KOMATSU

**Komatsu Europe
International NV**
Mechelsesteenweg 586
B-1800 VILVOORDE (BELGIUM)
Tel. +32-2-255 24 11
Fax +32-2-252 19 81
www.komatsu.eu

UESS12706 08/2012

Materials and specifications are subject to change without notice.
KOMATSU is a trademark of Komatsu Ltd. Japan.