

KOMATSU

PRELIMINARY

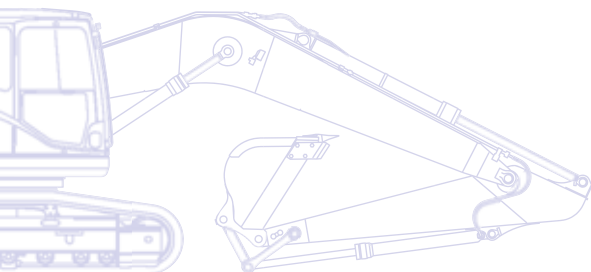

Hydraulic Excavator **PC228USLC-8**



ENGINE POWER
116 kW / 156 HP @ 2.000 rpm

OPERATING WEIGHT
22.730 - 23.280 kg

BUCKET CAPACITY
max. 1,49 m³

Walk-Around

The Komatsu PC228USLC-8 hydraulic excavator was designed with an ultra-short tail swing to meet the challenges of work in confined areas. With a near-zero tail swing radius, it's the ultimate machine for jobsite safety and is perfect for work on roadways, bridges, in urban areas, or anywhere with limited work space. The PC228USLC-8 delivers the quality, performance and productivity you can expect from Komatsu equipment.

Powerful and environmentally friendly

- Low consumption ecot3 engine
- Komatsu integrated hydraulic system
- Eco-gauge and idle caution
- Reduced wastage

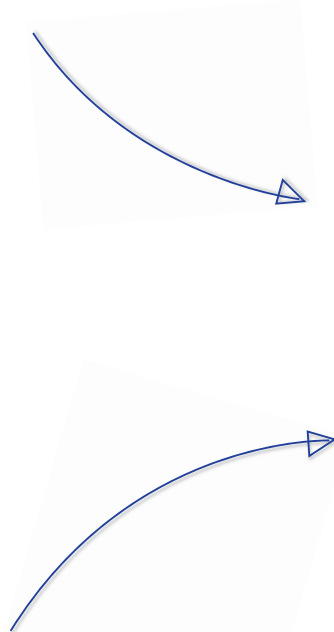

Quality you can rely on

- Reliable and efficient
- Rugged design
- Sliding door
- Komatsu-quality components
- Extensive dealer support network



ENGINE POWER
116 kW / 156 HP @ 2.000 rpm

OPERATING WEIGHT
22.730 - 23.280 kg

BUCKET CAPACITY
max. 1,49 m³

First-class operator comfort

- Wide, spacious cab
- Low noise design
- Low vibration levels
- Pressurised cab
- Large, widescreen TFT monitor panel

Highest safety standards

- Safe SpaceCab™
- ROPS compliant to ISO12117-2:2008
- Rear view camera
- Optimal jobsite safety
- Safe access, easy maintenance
- Falling Object Protection System (FOPS) optional

Total versatility

- Ultra-short tail swing
- Ideal for a wide range of applications
- 5 working modes
- Wide choice of options
- Built-in versatility



KOMTRAX

Komatsu Satellite
Monitoring System

Specifications

ENGINE

Model	Komatsu SAA6D107E-1
Type	Common rail direct injection, water-cooled, emissionised, turbocharged, after-cooled diesel
Engine power	
at rated engine speed	2.000 rpm
ISO 14396	116 kW / 156 HP
ISO 9249 (net engine power)	110 kW / 148 HP
No. of cylinders	6
Bore x stroke	107 x 124 mm
Displacement	6,69 ltr
Battery	2 x 12 V/120 Ah
Alternator	24 V/60 A
Starter motor	24 V/5,5 kW
Air filter type	Double element type with monitor panel dust indicator and auto dust evacuator
Cooling	Suction type cooling fan with radiator fly screen

HYDRAULIC SYSTEM

Type	HydrauMind. Closed-centre system with load sensing and pressure compensation valves
Additional circuits	Depending on the specification up to 2 additional circuits can be installed
Main pump	2 variable displacement piston pumps supplying boom, arm, bucket, swing and travel circuits
Maximum pump flow	2 x 219 ltr/min
Relief valve settings	
Implement	380 bar
Travel	380 bar
Swing	295 bar
Pilot circuit	33 bar

ENVIRONMENT

Engine emissions	Fully complies with EU Stage IIIA and EPA Tier III exhaust emission regulations
Noise levels	
LwA external	102 dB(A) (2000/14/EC Stage II)
LpA operator ear	72 dB(A) (ISO 6396 dynamic test)

OPERATING WEIGHT (APPR.)

Triple grouser shoes	Operating weight	Ground pressure
600 mm	22.730 kg	0,48 kg/cm ²
700 mm	23.000 kg	0,41 kg/cm ²
800 mm	23.280 kg	0,37 kg/cm ²

Operating weight, including 650 kg bucket, 2,9 m arm, operator, lubricant, coolant, full fuel tank and the standard equipment.

SWING SYSTEM

Type	Axial piston motor driving through planetary double reduction gearbox
Swing lock	Electrically actuated wet multi-disc brake integrated into swing motor
Swing speed	0 - 11,0 rpm

DRIVES AND BRAKES

Steering control	2 levers with pedals giving full independent control of each track
Drive method	Hydrostatic
Travel operation	Automatic 3-speed selection
Gradeability	70%, 35°
Max. travel speeds	
Lo / Mi / Hi	3,0 / 4,1 / 5,5 km/h
Maximum drawbar pull	20.600 kg
Brake system	Hydraulically operated discs in each travel motor

UNDERCARRIAGE

Construction	X-frame centre section with box section track frames
Track assembly	
Type	Fully sealed
Shoes (each side)	49
Tension	Combined spring and hydraulic unit
Rollers	
Track rollers (each side)	9
Carrier rollers (each side)	2

SERVICE REFILL CAPACITIES

Fuel tank	320 ltr
Radiator	21 ltr
Engine oil	23,1 ltr
Swing drive	7,1 ltr
Hydraulic tank	137 ltr
Final drive (each side)	5,2 ltr



MACHINE DIMENSIONS	MONO BOOM
A Overall width of upper structure	2.980 mm
B Overall height of cab	3.050 mm
C Overall length of basic machine	4.450 mm
D Tail length	1.680 mm
Tail swing radius	1.680 mm
E Clearance under counterweight	1.060 mm
F Machine tail height (to top of engine cover)	2.400 mm
G Ground clearance	440 mm
H Tumbler centre distance	3.655 mm
I Track length	4.450 mm
J Track gauge	2.380 mm
K Track shoe width	600, 700, 800 mm
L Overall track width with 600 mm shoe	2.980 mm
Overall track width with 700 mm shoe	3.080 mm
Overall track width with 800 mm shoe	3.180 mm

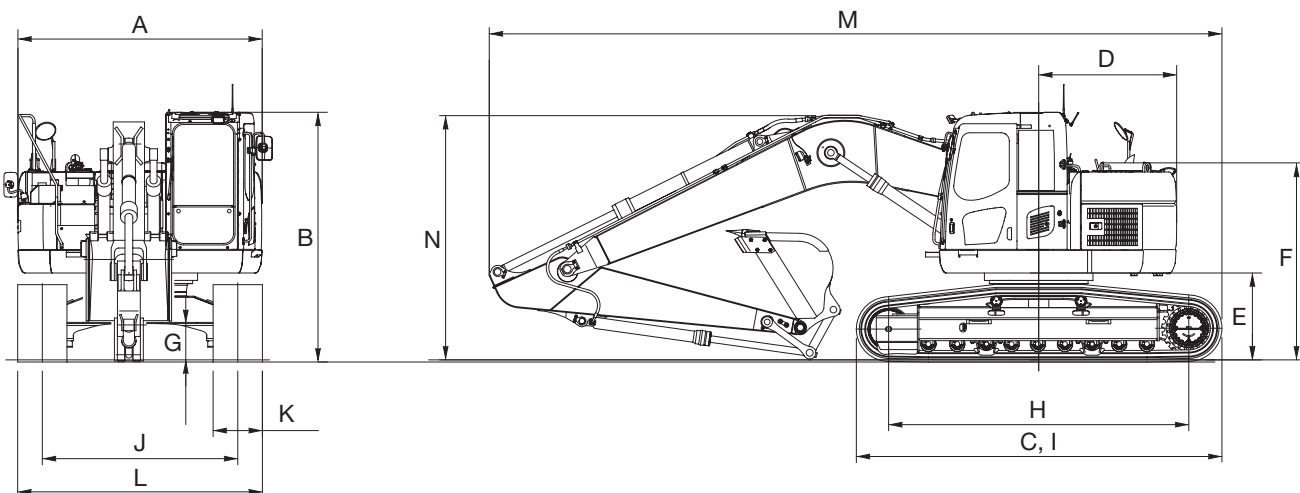
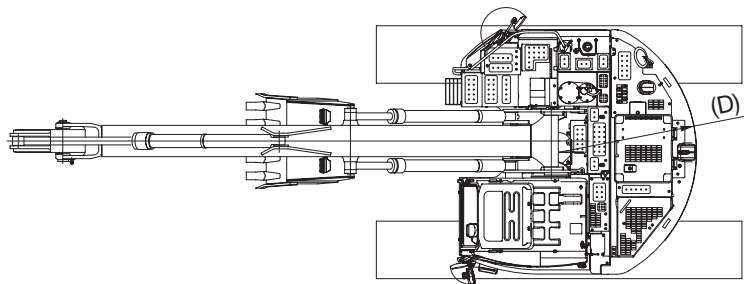

MONO BOOM		
Arm length	2,4 m	2,9 m
M Transport length	8.950 mm	8.890 mm
N Overall height (to top of boom)	3.170 mm	2.980 mm

Working Range

MONO BOOM

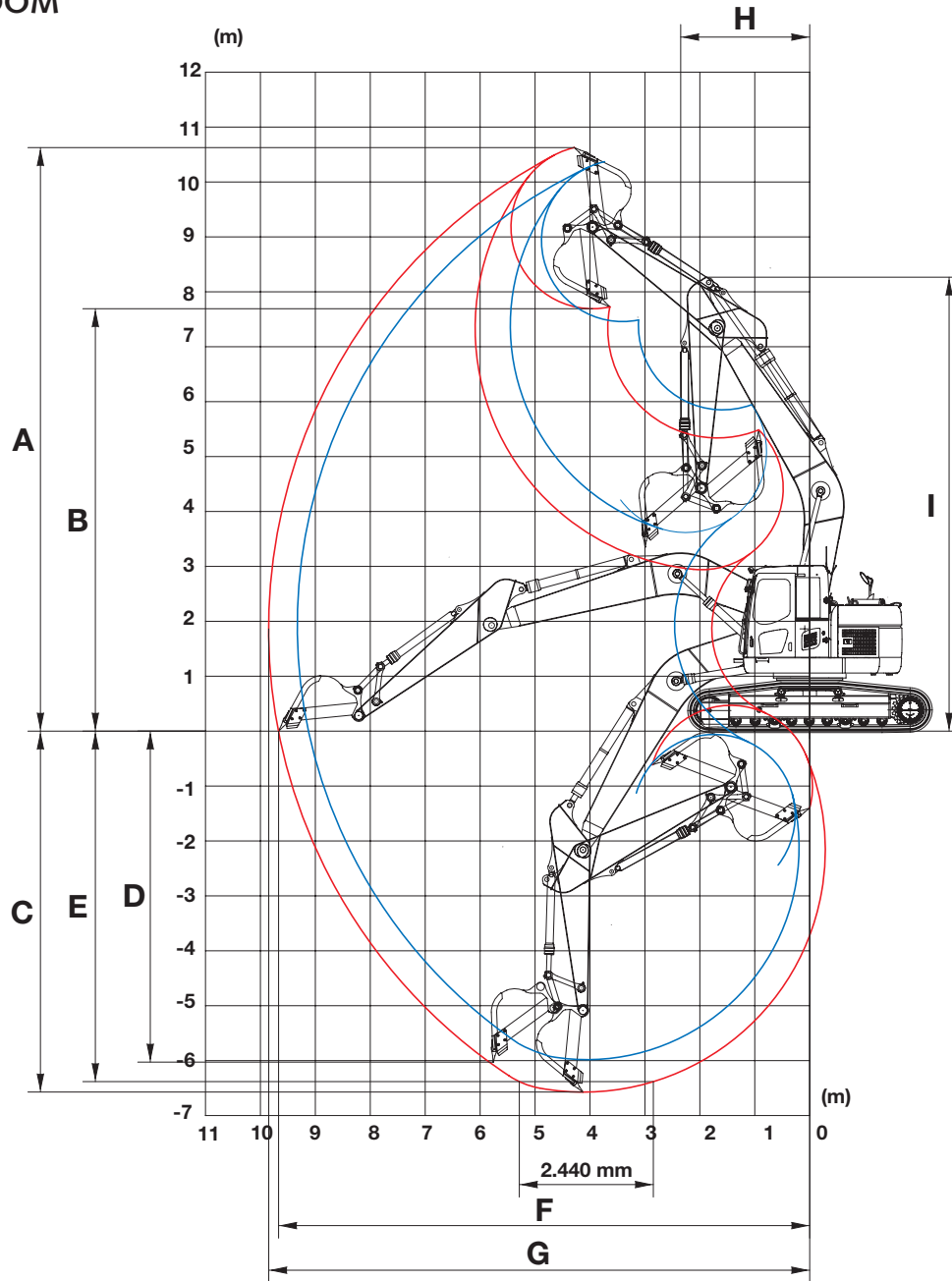

ARM LENGTH	2,4 m	2,9 m
A Max. digging height	10.380 mm	10.700 mm
B Max. dumping height	7.470 mm	7.825 mm
C Max. digging depth	6.095 mm	6.620 mm
D Max. vertical wall digging depth	5.315 mm	5.980 mm
E Max. digging depth of cut for 2,44 m level	5.840 mm	6.370 mm
F Max. digging reach	9.395 mm	9.875 mm
G Max. digging reach at ground level	9.205 mm	9.700 mm
H Min. swing radius	2.700 mm	2.310 mm
H Max. height at min. swing radius	8.340 mm	8.250 mm
Arm crowd force at PowerMax	13.000 kg	11.000 kg
Bucket digging force at PowerMax	17.500 kg	15.200 kg

MONO BOOM

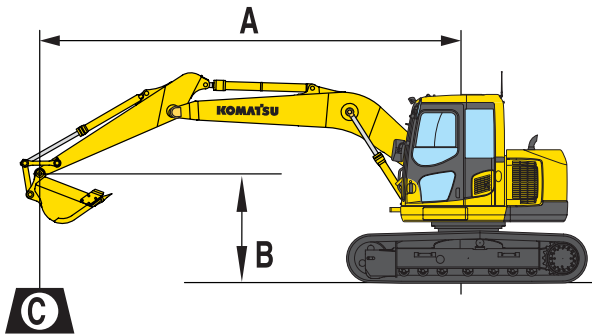

A – Reach from swing center

B – Bucket hook height

C – Lifting capacities, including bucket (650 kg), bucket linkage and bucket cylinder













When removing bucket, linkage or cylinder, lifting capacities can be increased by their respective weights



With 700 mm shoes



 – Rating over front

 – Rating over side

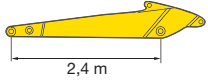
 – Rating at maximum reach

Arm length	A			7,5 m		6,0 m		4,5 m		3,0 m		1,5 m	
	B												

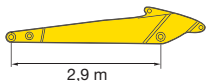
 2,4 m  650 kg 0,8 m ³	6,0 m	kg	*4.250	3.400			*4.720	4.530	*4.750	*4.750				
	4,5 m	kg	*4.290	2.780	*4.980	2.910	*5.310	4.350	*6.210	*6.210	*8.000	*8.000		
	3,0 m	kg	4.340	2.470	4.890	2.800	*6.280	4.080	*8.480	6.540				
	1,5 m	kg	4.190	2.350	4.760	2.680	6.850	3.870	*10.380	6.030				
	0,0 m	kg	4.300	2.400	4.660	2.600	6.660	3.710	10.800	5.760	*6.970	*6.970		
	-1,5 m	kg	4.760	2.650	4.640	2.580	6.580	3.640	10.710	5.690	*9.250	*9.250	*7.680	*7.680
	-3,0 m	kg	5.870	3.280			6.640	3.680	*10.360	5.790	*14.680	11.850	*10.940	*10.940
-4,5 m	kg	*7.210	5.070					*8.420	6.050	*11.870	*11.870			

 2,9 m  650 kg 0,8 m ³	6,0 m	kg	*2.780	*2.780	*3.110	3.040	*4.200	*4.200						
	4,5 m	kg	*2.810	2.530	*4.580	2.990	*4.840	4.470	*5.430	*5.430				
	3,0 m	kg	*2.960	2.270	4.960	2.860	*5.860	4.200	*7.670	6.750	*11.480	*11.480		
	1,5 m	kg	*3.250	2.160	4.800	2.720	6.900	3.950	*9.790	6.190	*6.860	*6.860		
	0,0 m	kg	*3.760	2.190	4.690	2.620	6.720	3.750	10.790	5.840	*5.200	*5.200		
	-1,5 m	kg	4.310	2.390	4.640	2.570	6.600	3.650	10.730	5.700	*9.300	*9.300	*5.180	*5.180
	-3,0 m	kg	5.160	2.870			6.600	3.650	*10.710	5.740	*14.820	11.680	*9.740	*9.740
-4,5 m	kg	*6.870	4.100					*9.320	5.940	*13.300	*11.920			

* Load is limited by hydraulic capacity rather than tipping.

Ratings are based on SAE Standard No. J1097.

Rated loads do not exceed 87% of hydraulic lift capacity or 75% of tipping load.

MAX. BUCKET CAPACITY AND WEIGHT

Arm length	MONO BOOM			
	2,4 m		2,9 m	
Material weight up to 1,2 t/m ³	1,49 m ³	1.075 kg	1,37 m ³	1.000 kg
Material weight up to 1,5 t/m ³	1,27 m ³	950 kg	1,18 m ³	900 kg
Material weight up to 1,8 t/m ³	1,10 m ³	875 kg	1,00 m ³	825 kg

Max. capacity and weight have been calculated according to ISO 10567:2007.

Please consult with your distributor for the correct selection of buckets and attachments to suit the application.

Hydraulic Excavator

PC228USLC-8

Standard and Optional Equipment

ENGINE

Komatsu SAA6D107E-1 turbocharged common rail direct injection diesel engine, EU Stage IIIA compliant	●
Suction type cooling fan with radiator fly screen	●
Automatic engine warm-up system	●
Engine overheat prevention system	●
Fuel control dial	●
Auto-deceleration function	●
Engine key stop	●
Engine ignition can be password secured on request	●
Alternator 24 V/60 A	●
Starter motor 24 V/5,5 kW	●
Batteries 2 × 12 V/120 Ah	●

HYDRAULIC SYSTEM

Electronic closed-centre load sensing (E-CLSS) hydraulic system (HydrauMind)	●
Pump and engine mutual control (PEMC) system	●
5-working mode selection system; Power mode, economy mode, breaker mode, attachment mode and lifting mode	●
One additional 2-way full-flow service spool with attachment lines on boom and arm and pedal in cab (HCU A)	●
Adjustable PPC wrist control levers for arm, boom, bucket and swing, with sliding proportional control for attachments and 3 auxiliary buttons	●
Quick-coupler piping	●
Additional hydraulic circuit	○

UNDERCARRIAGE

Track frame under-guards	●
600 mm triple grouser shoes	●
700, 800 mm triple grouser shoes	○
600 mm road-liner (rubber) shoes	○
Full length track roller guards	○

CABIN

Reinforced safety SpaceCab™; ROPS compliant to ISO12117-2:2008. Highly pressurised and tightly sealed hyper viscous mounted cab with tinted safety glass windows, large roof hatch, pull-up type front window with locking device, removable lower window, front window wiper with intermittent feature, cigarette lighter, ashtray, luggage shelf, floor mat	●
Heated, high back air suspension seat with lumbar support, height adjustable arm rests and retractable seat belt	●
Automatic climate control system	●
12 Volt power supply	●
Beverage holder	●
Radio	●
Lower wiper	○

SERVICE AND MAINTENANCE

Automatic fuel line de-aeration	●
Double element type air cleaner with dust indicator and auto dust evacuator	●
KOMTRAX™ - Komatsu satellite monitoring system	●
Multi-function video compatible colour monitor with Equipment Management and Monitoring System (EMMS) and efficiency guidance	●
Toolkit and spare parts for first service	●

DRIVES AND BRAKES

Hydrostatic, 3-speed travel system with automatic shift and planetary gear type final drives, and hydraulic travel and parking brakes	●
PPC control levers and pedals for steering and travel	●

WORK EQUIPMENT

Mono boom	●
2,4 m; 2,9 m arms (HCU assembly includes piping for one additional function)	○
Komatsu buckets	○
Komatsu breakers	○

SAFETY EQUIPMENT

Rear view camera system	●
Electric horn	●
Overload warning device	●
Lockable fuel cap and covers	●
Audible travel alarm	●
Boom safety valves	●
Large handrails, rear-view mirrors	●
Battery main switch	●
Arm safety valve	○
OPG Level II front guard (FOPS)	○
OPG Level II top guard (FOPS)	○

LIGHTING SYSTEM

Working lights: 1 revolving frame and 1 boom (r.h.)	●
Additional working lights: 5 cab roof, 1 boom (l.h.), 1 counterweight (rear), additional revolving frame (l.h.), beacon and harness for 2 lamps (not included) in boom foot area	○

OTHER EQUIPMENT

Remote greasing for swing circle and pins	●
Electric refuelling pump with automatic shut off function	●
Standard colour scheme and decals	●
Parts book and operator manual	●

Further equipment on request

- standard equipment
- optional equipment

Your Komatsu partner:

KOMATSU

Komatsu Europe International NV
 Mechelsesteenweg 586
 B-1800 VILVOORDE (BELGIUM)
 Tel. +32-2-255 24 11
 Fax +32-2-252 19 81
www.komatsu.eu

UESS14200P 07/2010

Materials and specifications are subject to change without notice.
KOMATSU is a trademark of Komatsu Ltd. Japan.

– PRELIMINARY VERSION. ALL DATA NON-BINDING. –

Printed in Europe – This specification sheet may contain attachments and optional equipment that are not available in your area.
 Please consult your local Komatsu distributor for those items you may require. Materials and specifications are subject to change without notice.