

KOMATSU

PC
35MR



Mini-Excavator **PC35MR-3**

ENGINE POWER
22,0 kW / 29,5 HP @ 2.400 rpm

OPERATING WEIGHT
3.575 - 3.835 kg

BUCKET CAPACITY
0,035 - 0,13 m³

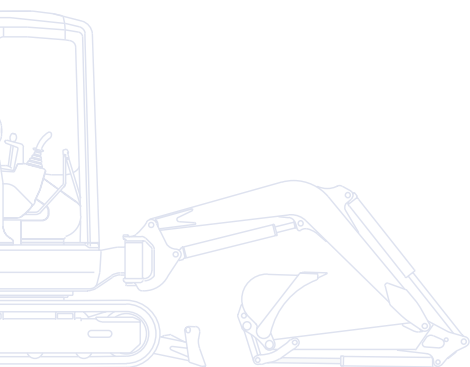

Walk-Around

The new PC35MR-3 compact mini-excavator is the result of the competence and technology that Komatsu has acquired over the past 80 years. It was designed and developed with constant attention to the needs of customers from all over the world. The end product is a user-friendly machine with top-class performances.

Total versatility

- Customised configurations
- Standard 1 or 2 way auxiliary line for attachments
- Ideal for a wide range of applications



Cutting-edge hydraulic circuit

- CLSS (Closed-centre Load Sensing System)
- Perfect control even during combined operations
- Fast and precise movements



PC35MR-3

ENGINE POWER
22,0 kW / 29,5 HP @ 2.400 rpm

OPERATING WEIGHT
3.575 - 3.835 kg

BUCKET CAPACITY
0,035 - 0,13 m³

First-class operator comfort

- Spacious working environment
- Sliding door
- Pressure Proportional Control (PPC) servo-controls



Outstanding performances

- Optimal power and digging speed
- Superior stability and safety in any conditions
- Fast and precise movements



Easy maintenance

- Quick access to all daily inspection points
- Tilting cab for maintenance jobs
- Extended 500-hour service interval

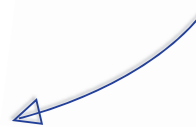

KOMTRAX

Komatsu Satellite
Monitoring System

Outstanding Performances



Work in tight spaces

The new short-tail PC35MR-3 delivers optimal power and digging speed, even in confined spaces where traditional machines can't work: yards, road works, demolition sites, sewers, etc. Sturdy and very stable, it guarantees maximum safety and offers complete operator confidence in any working conditions.

Automatic down-shift

This feature automatically adjusts the hydraulic travel motor for the job at hand: maximum displacement for faster movement, or minimum displacement for high drawbar pull. This process requires no attention from the operator. The two-speed tracking is operated via a switch on the blade lever.

X-frame

The new X-frame ensures maximum stress resistance and optimal stress distribution. Its shape makes the machine a lot more rigid and reliable. In addition, it facilitates the regular undercarriage cleaning operations and the spoils removal process.



Cutting-Edge Hydraulic Circuit

Komatsu CLSS

The CLSS (Closed-centre Load Sensing System) hydraulic circuit guarantees power, speed and perfect control to all movements, including simultaneous ones. The combination of the variable displacement pump and of CLSS allows operators to perform all

required movements with maximum efficiency, regardless of the load or rpm. The unique CLSS characteristics are perfectly complemented by the hydraulic servo-controls, which are, by far, the easiest to use and that allow extremely precise manoeuvres with minimal effort.



First-Class Operator Comfort



An optimal work environment

Despite its compact size, the PC-35MR-3 offers unequalled comfort. The spacious cab was developed with exceptional care to details, and the work environment is quiet and comfortable. Special attention is given to the operator: ergonomic and dedicated PPC controls, and, in option, an efficient air conditioning and ventilation system to guarantee optimal thermal comfort. Last, but not least, the upper rail sliding door makes getting in and out of the machine very easy and safe in any situation.





Customisation

Many configurations are available, so you can choose the perfect machine for the job: long or short arm, cab or canopy, rubber, steel or road liner shoes. The 1 / 2 way auxiliary hydraulic circuit allows the use of a wide range of working tools such as a hammer, a clamshell bucket, an auger etc.

The switch between the two options is simply done by means of a valve located under a little bonnet on the side of the machine.



Easy Maintenance

Tilting cab

The wide opening engine bonnets provide a quick access to daily inspection points. The fuel and the hydraulic oil tanks are located under the side bonnet, in a safe and easy-to-reach position. In addition, the cab easily tilts back for major maintenance tasks.

Easier repairs

ORFS hydraulic face seal connectors and DT electrical connectors enhance the machine's reliability and make repairs faster and easier. Special technical solutions allow the interval for most ordinary maintenance operations - such as pin greasing and engine oil changes - to be extended up to 500 hours.



Rear bonnets for quick engine checks, simple inspections, cleaning of the radiators and easy access to the battery



Front bonnet: fuel tank refilling

Komatsu Satellite Monitoring System



KOMTRAX™ is a revolutionary machine tracking system designed to save you time and money. You can now monitor your equipment anytime and anywhere. Use valuable machine data received via the KOMTRAX™ web site to optimise your maintenance planning and machine performances.

With KOMTRAX™, you can:

- Check when & where your machines are at work
- Be informed of unauthorized machine use or movement
- Set and receive e-mail notification for security alarms

For further details on KOMTRAX™, please ask your Komatsu dealer for the latest KOMTRAX™ brochure.



Machine working time - With the "daily working record" chart, get precise engine running time data: when your machine was started and when it was shut down, as well as total engine running time.



Fleet location - The machine list instantly locates all your machines, even those in other countries.



Alarm notifications - You can receive notification of alarms both via the KOMTRAX™ website and by e-mail.



Added security - The "engine lock" feature allows to program when a machine's engine can be started. And with "geo-fence", KOMTRAX™ sends notification every time your machine moves in or out of a predetermined operating area.

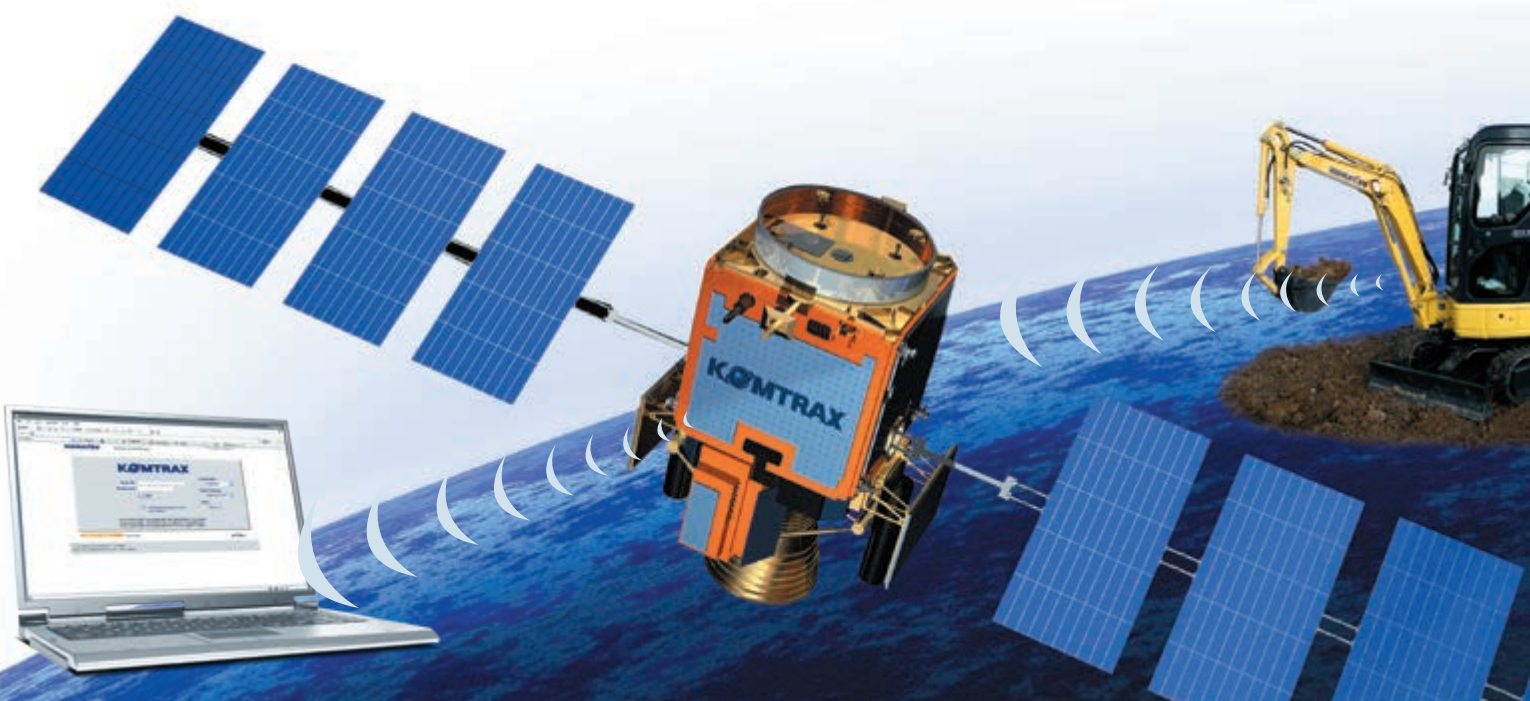

Specifications

ENGINE

The new generation engine has been developed to comply with the strictest emission controls.

Model	Komatsu 3D88E
Type	emissionised 4-cycle diesel engine
Displacement.....	1.642 cm ³
Bore × stroke.....	88 × 90 mm
No. of cylinders	3
Engine power	
at rated engine speed.....	2.400 rpm
ISO 14396.....	22,0 kW / 29,5 HP
ISO 9249 (net engine power)	21,6 kW / 29,0 HP
Max. torque/engine speed	105,1 Nm/1.440 rpm
Cooling system.....	water
Air filter type	dry
Starter motor	electric motor with pre-heating air system for cold climate

OPERATING WEIGHT

Operating weight with standard bucket, fully serviced, +75 kg operator (ISO 6016).

Operating weight with cab and rubber shoes	3.725 kg
Operating weight with cab and steel shoes	3.835 kg
Canopy	-150 kg (optional)

HYDRAULIC SYSTEM

Type	Komatsu CLSS
Main pump	2 × variable displacement pump
Max. pump flow.....	36,1 × 2 + 19,8 ltr/min
Max. operating pressure.....	26 MPa (260 bar)

Hydraulic motors:

Travel.....	2 × variable displacement
Swing.....	1 × fixed displacement

Hydraulic cylinders (bore × stroke):

Boom	80 × 585 mm
Arm	75 × 595 mm
Bucket.....	65 × 490 mm
Boom swing.....	95 × 482 mm
Blade.....	95 × 140 mm

Bucket digging force (ISO 6015)

Arm crowd force (ISO 6015):

1.370 mm arm.....	2.058 daN (2.100 kg)
1.720 mm arm.....	1.637 daN (1.670 kg)

The digging equipment is fully controlled by PPC servo-controls. All movements are stopped by lifting the safety levers on the tilting case.

ENVIRONMENT

Vibration levels (EN 12096:1997)

Hand/arm	≤ 2,5 m/s ² (uncertainty K = 0,56 m/s ²)
Body	≤ 0,5 m/s ² (uncertainty K = 0,23 m/s ²)

Contains fluorinated greenhouse gas HFC-134a (GWP 1430).

Quantity of gas 0,6 kg, CO₂ equivalent 0,86 t.

SWING SYSTEM

The rotation is operated by means of an orbital hydraulic motor. Single ball-bearing ring with internal, induction hardened toothring.

Centralised lubrication of the unit.

Swing speed..... 9,0 rpm

BLADE

Type

 electro-welded, single unit structure

Width × height

 1.740 × 355 mm

Max. lifting above ground level

 360 mm

Max. depth below ground level

 390 mm

UNDERCARRIAGE

Central lower X-frame and carriage frame with boxed section.

Track rollers (each side).....

 4

Shoe width

 300 mm

Ground pressure (standard).....

 0,36 kg/cm²

ELECTRIC SYSTEM

Voltage.....

 12 V

Battery

 68 Ah

Alternator.....

 40 A

Starter motor

 2,3 kW

SERVICE CAPACITIES

Fuel tank

 44 ltr

Radiator and system

 3,3 ltr

Engine oil (refill).....

 7,2 ltr

Hydraulic system.....

 39 ltr

TRANSMISSION

Type

 2 speed hydrostatic transmission, controlled and
 steered by means of two levers and two pedals

Hydraulic motors

 2 × axial pistons

Reduction system.....

 planetary gear

Max. drawbar pull.....

 3.530 daN (3.600 kgf)

Travel speed

 2,8 - 4,8 km/h

Dimensions & Working Range

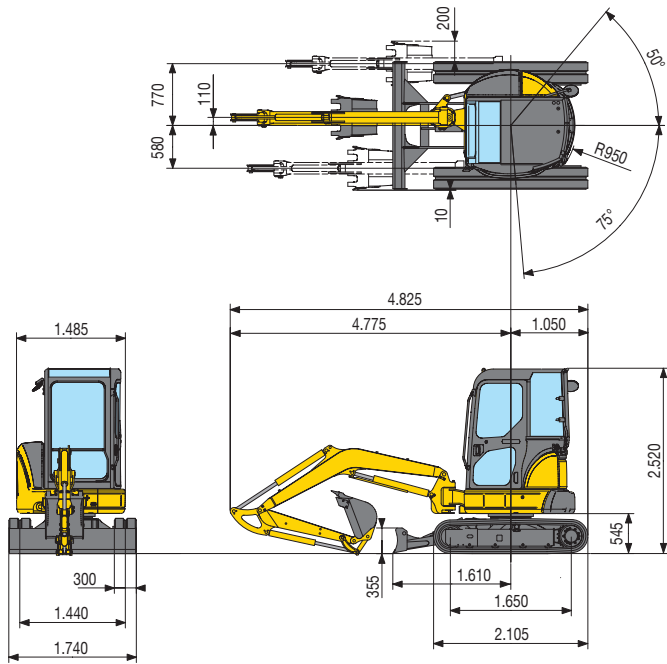

BUCKET RANGE

Width mm	Capacity m ³ (ISO 7451)	Weight kg	No. of teeth
300	0,035	55	2
400	0,07	65	3
500	0,095	80	4
600	0,12	90	5
650	0,13	95	5

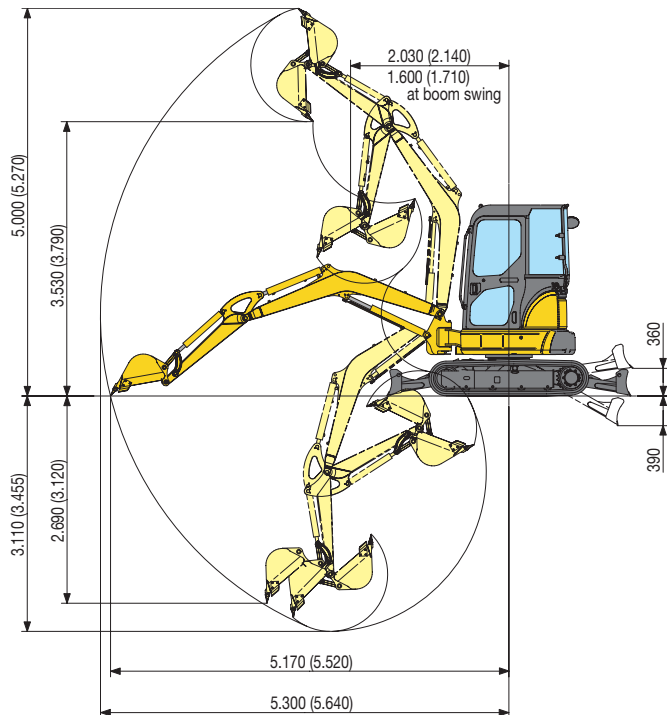

Cab, rubber shoes, blade down

A - Distance from machine's center B - Height at bucket pin

ARM LENGTH 1.370 mm

A	2 m		3 m		4 m		Max. outreach	
	Front	360°	Front	360°	Front	360°	Front	360°
4 m	-	-	(*)715	(*)715	-	-	(*)705	635
3 m	-	-	(*)710	(*)710	(*)720	440	(*)700	420
2 m	-	-	(*)965	700	(*)775	435	(*)720	350
1 m	-	-	(*)1.300	655	(*)890	420	(*)855	370
0 m	(*)2.630	1.190	(*)1.445	630	(*)945	410	(*)895	385
-1 m	(*)2.260	1.205	(*)1.335	630	-	-	(*)930	455
-2 m	(*)1.455	1.245	-	-	-	-	(*)900	710

Unit: kg

ARM LENGTH 1.720 mm

A	2 m		2,5 m		3 m		Max. outreach	
	Front	360°	Front	360°	Front	360°	Front	360°
4 m	-	-	-	-	-	-	(*)630	535
3 m	-	-	-	-	(*)615	455	(*)640	385
2 m	-	-	(*)820	720	(*)700	445	(*)665	325
1 m	-	-	(*)1.190	670	(*)840	430	(*)700	305
0 m	(*)2.780	1.190	(*)1.420	635	(*)935	415	(*)745	315
-1 m	(*)2.515	1.195	(*)1.400	630	(*)910	410	(*)795	365
-2 m	(*)1.870	1.225	(*)1.085	640	-	-	(*)845	525

Unit: kg

NOTE:

Ratings are based on ISO standard 10567. Rated loads do not exceed 87% of hydraulic lift capacity or 75% of tipping load. Excavators used in object handling operations must comply with the related local regulations and must be equipped with hose burst valves (boom & arm) and an overload warning device in compliance with EN474-5.

- The values marked with an asterisk (*) are limited by the hydraulic capacities.
- Calculations are based on the machine resting on a uniform and firm surface.
- The lifting point is a hypothetical hook placed behind the bucket.

Mini-Excavator

PC35MR-3

Standard Equipment

- ROPS (ISO 3471) / FOPS (ISO 10262) tilting cab with heating
- Sliding door
- 300 mm rubber shoes
- 1.370 mm digging arm
- Two speeds with "Automatic Shift Down"
- 1 / 2 way auxiliary hydraulic circuit up to the arm
- Blade
- Adjustable suspension seat
- Lifting cylinder guard
- Working light on boom
- 2 rear-view mirrors
- Travel acoustic alarm
- KOMTRAX™ - Komatsu satellite monitoring system
- Boom and arm safety valves, overload warning device (for EU countries only)

Optional Equipment

- ROPS (ISO 3471) / FOPS (ISO 10262) canopy
- 300 mm steel shoes
- 300 mm road liners
- 1.720 mm digging arm
- Air conditioning
- Bucket range (300 - 650 mm)
- 1.300 mm ditch cleaning bucket
- Valves on bucket cylinder
- Bucket linkage with lifting eye
- Boom and arm safety valves, overload warning device (for non-EU countries only)
- Blade safety valve
- Relieve valves for attachments
- Rotating beacon
- Rear-view mirrors
- Cab/canopy working lights
- Additional cab rear working light
- Proportional controls for attachment on joystick
- Radio pre-setting
- Komatsu mechanical quick-coupler
- Buckets with Kmax teeth

Your Komatsu partner:

KOMATSU

**Komatsu Europe
International NV**
Mechelsesteenweg 586
B-1800 VILVOORDE (BELGIUM)
Tel. +32-2-255 24 11
Fax +32-2-252 19 81
www.komatsu.eu

WESS003008 01/2017

Materials and specifications are subject to change without notice.
KOMATSU is a trademark of Komatsu Ltd. Japan.