

KOMATSU

WA
250



WA250-5/PT-5

WA250-5 / WA250PT-5

WHEEL LOADER / PARALLEL TOOL CARRIER

NET HORSEPOWER
101 kW 135 HP

OPERATING WEIGHT
max. 13.800 kg

BUCKET VOLUME
2,0 - 4,0 m³

AT A GLANCE

The new WA250-5 & WA250PT-5 wheel loaders: The perfect combination of performance, comfort and economy. Never-before experienced comfort in the SpaceCab cabin, enormous tractive force and lowest fuel consumption due to an innovative and efficient hydrostatic drive-line concept. Whisper-quiet in use, almost maintenance-free and incredibly productive. These are wheel loaders that clearly earned 5 stars!

Excellent Driving Convenience

- SpaceCab™ cabin
- Optimum all-around view
- Interior sound level is only 72 dB(A)
- Series production electric controlled air conditioning as standard
- Electronically controlled HST with variable shift control system
- Traction Control System (TCS)
- Adjustable steering column
- Air-cushioned driver seat
- PPC short levers with F/R switch
- PPC-Multifunction lever with integrated F/R switch (option)

Overwhelming Efficiency

- High-torque low-emission engine with intercooler
- Extremely low fuel consumption
- Highest tractive effort
- Large breakout force
- Electronically controlled HST-drive (hydrostatic) with 2-motor system
- ECSS load stabiliser (option)



Diverse and Flexible

- Comprehensive range of attachments for a wide variety of uses

Ecological

- Meets Step II emission regulations in Europe and USA
- Exterior sound level 106 dB(A)*
- More than 95% of all materials can be recycled

The 5 Star Loader

WA250-5

WHEEL LOADER

NET HORSEPOWER

101 kW 135 HP

OPERATING WEIGHT

max. 13.800 kg

BUCKET VOLUME

2,0 - 4,0 m³

WA250PT-5

- Fully integrated market compatible quick coupler as standard
- High tilt-back force due to optimal parallel loader link
- 2-mode return-to-dig setting for bucket or fork
- 2-stage variable dump speed setting



Long Service Life and Reliable

- Reliable original Komatsu components
- Robust torsionally resistant frame
- Maintenance-free fully hydraulic, wet disc service and parking brakes
- Heavy-duty Torque Proportional Axles
- Sealed DT wiring harness connector
- Electronically controlled HST with overrun protection system

Easy Maintenance

- EMMS monitoring system
- Swing-out fan drive
- Side-by-side type radiators for easy access and cleaning
- Gull-wing doors for easy ground level access
- Extended engine oil change interval
- Factory fitted automatic lubrication system (option)

HIGH PRODUCTIVITY

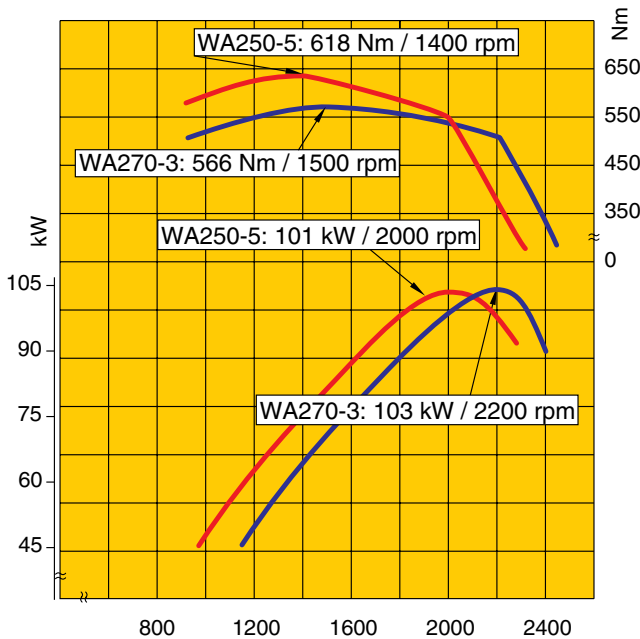

High torque at low engine speeds

The net output of the Komatsu SAA6D102E low-emission engine is 101 kW (135 HP) at only 2.000 rpm. This means a constant, high power output with a 10% reduction in engine speed, compared with its predecessor. The increased engine torque and the new hydrostatic drive line (HST) contribute to a substantial improvement in fuel consumption and climbing abilities. In load & carry as well as in loading operations, faster work cycles are achieved with simultaneous savings in fuel costs.

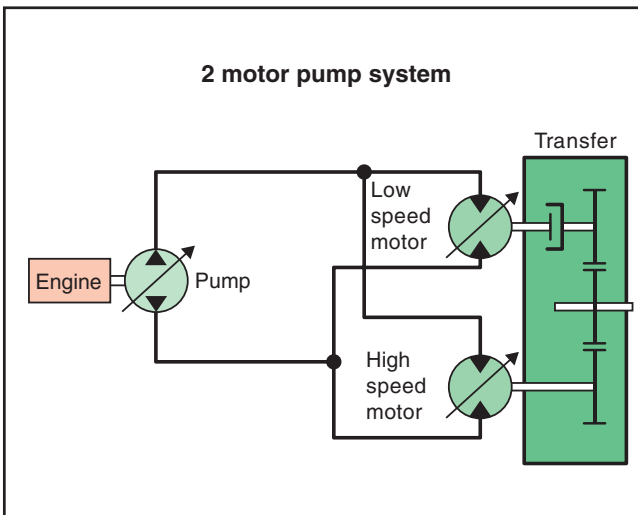

Electronically controlled HST

The electronically controlled variable 2 pump motor system allows high-efficient and powerful operation. When the vehicle is travelling at high speed, the power transmitted between low-speed motor and axle is automatically cut off by the clutch for eliminating a drag-turning of the low-speed motor. Starting, gearshifting and piling-up on a slope is easy because there is no torque-off in the power train. Digging and scooping is easy as well, since maximum rimpull can be demonstrated even from zero travel speed.



Maximum dumping height and reach

The long lifting frame allows an enormous dumping height of 2.905 mm and a reach of 1.020 mm that is just as impressive (WA250-5, with 2,1 m³ universal bucket, measured to the cutting edge). With this working range, even loading high-sided semi-trailers becomes child's play.

BUCKETS AND ATTACHMENTS

The WA250-5 and WA250PT-5 are outstanding due to their versatility. Whether used industrially in structural or civil engineering, earthmoving, road construction, agriculture, forestry or the timber industry, in landscaping companies and nurseries or in community services, the right solution is always available for your requirements.

The hydraulically operated, market compatible 4-point quick-coupler as standard equipment (option on the WA250-5) guarantees the machine's versatility and thus makes high-intensity operation possible. Examples from the comprehensive range of original attachments are:



Universal bucket

This type of bucket is impressive because of its excellent penetration and loosening properties and its good material holding properties. This universal bucket can be equipped with flush mount adapters and interchangeable teeth.



Earthmoving bucket

The earthmoving bucket with a one-piece bucket bottom is suited both for earthworks and loading cohesive material. The slanted sides give powerful penetration. It is equipped either with flush mount adapters and interchangeable teeth or also with a rear removable edge.



High dump bucket

For maximum dumping heights with light materials like coal or woodchips. The dump cylinders are located either inside or outside the bucket.



Log grapple

Various versions available. With its sturdy structure and its great hydraulic power, the WA250 is also perfectly suited to work in the timber industry.



Mulch grab bucket

Perfectly suited for picking up bulky and compressible materials like gardening or plastic waste, etc. Without the side plates, this bucket can be used also as a grapple.



Sweepers

Hydraulically operated, with optional waste collecting bin and spraying device. Easy operation with the WA250 due to its variable speed control.

GREATER VERSATILITY



2 modes for dump speed and return-to-dig (WA250PT-5)

The 2 selection buttons for dumping speed and return-to-dig allow easier handling of heavy or complex front attachment. One button selects the attachment (bucket or fork), the second button changes the dump speed (slow or fast).



Traction Control System (TCS)

If the operator activates the traction control system, the maximum tractive effort is limited to 80%. This prevents tire slip at light duty operations like stockpiling or on sandy ground and reduces tire abrasion.



LONGEVITY AND RELIABILITY

Quality you can rely on!

The engine, hydraulics, power train, front and rear axles are original Komatsu components. All of these component parts are subject to the highest quality requirements and strict quality assurance right down to the smallest screw. They are fully co-ordinated with one another, thus offering maximum efficiency and reliability.

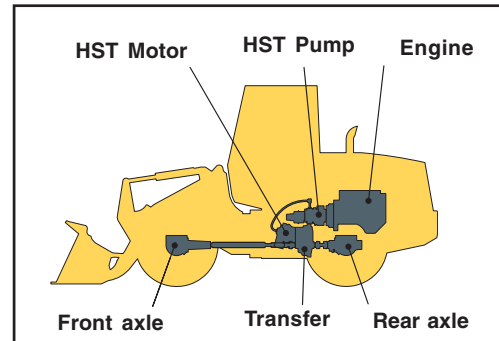

Torsionally resistant frame

The frame design with hinge points far apart guarantees the high stability for the overall construction and reduces bearing stress in the torsional ranges. Steering angles of 40° give the WA250-5 a high degree of manoeuvrability.



Robust HD-axes with TPD or LSD differential

The heavy-duty axles allow above-average service life even under the hardest working conditions. The WA250-5 can be equipped with torque proportional or multiple-disc limited slip differentials to further increase tractive force.



Reliable construction equipment engines

Komatsu's reliable engine, with thick walled crank case, was developed with low noise and robustness in mind. The integrated overrun protection system restricts the top speed when driving downhill, thus protecting the power train and drive system.



Reliability right down to the details

All of the hydraulic connections are reliably protected against oil loss by Komatsu's O-ring seals. The electrical system is also designed for long-lasting operation (without breakdowns) with its dust- and water-proof DT plug-and-socket connections in the wiring harnesses.

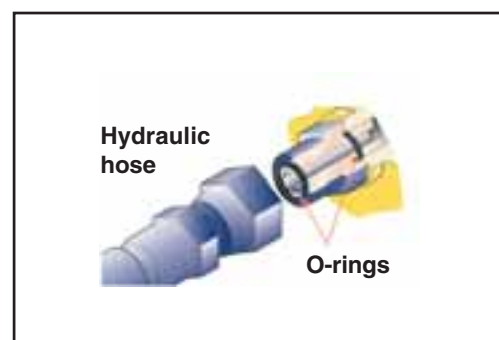

SIMPLE AND FAST MAINTENANCE



Simple and convenient access to service

The service doors are designed as gull-wing doors. They allow you convenient and safe access to the daily service points from the ground.



Easy maintenance due to swing-out fan

The swing-out cooling fan allows quick and easy cleaning of the radiator. The fan is hydraulically driven and separated from the engine compartment.

This innovative system features:

- Swing-out cooling fan for excellent access
- High-efficiency fan and shroud
- Very low-noise operation



EMMS (Equipment Management Monitoring System)

This completely new type of monitoring system is clearly structured and easy to read because it is directly in the operators field of view. If there is a malfunction, it immediately displays the details in the chosen national language and in plain text in the display field. This system not only has an error memory and a self-diagnosis function, but also a service interval display. This significantly simplifies service work and the operator is notified on time of the regular oil and filter changes. This means that the operator and customer-service engineer are constantly informed about the optimum machine state so that problems don't even occur in the first place.

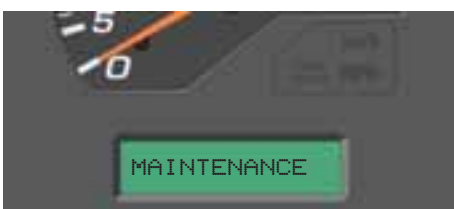

Maintenance-free braking system

The fully hydraulic dual-circuit service brake with multi-disc brakes running in an oil bath offers you the highest degree of safety and a long service life. The benefits of the new system are that weathering has no effect on it, it is available for work immediately after starting the engine and it is maintenance free. The operating brake actuates on all four wheels via the hydrostatic drive. The multi-disc internal parking brake is also maintenance free.

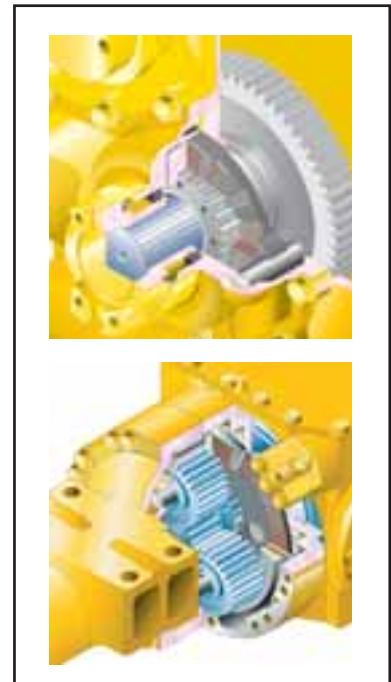

Automatic central lubrication system (Option)

The automatic lubrication system reduces the daily service work to the absolute minimum. Its robust hoses with protective equipment in all areas ensures consistent lubrication amounts, operating reliability and electronic monitoring with a malfunction signal at the grease pump. This increases the machine's service readiness and service life while lowering repair and service costs.



Customer service and spare parts supply

When you buy a Komatsu construction machine, you buy a lot more than just the product alone. Our service support accompanies you throughout the entire life of your wheel loader. Programs for preventative maintenance are just as much a part of what we offer as the complete range of dealer service and repair programmes. And, if there is a malfunction, Komatsu's close-knit network of dealers and excellent parts service ensures you minimum downtime.



THE SPACECAB



Perfect driving convenience and the best all-round visibility

The cabin is one of the largest in its class and offers unparalleled driving convenience comparable to that of a passenger car. The large frameless windscreen ensures an optimum view of the bucket and tires. The slanted rear end gives an excellent view towards the rear. The cabin is mounted on viscose shock absorbers guaranteeing a low interior sound level. That together with air conditioning as standard ensures the operator's well-being just as much as the air-cushioned multi-adjustable drivers seat with optional seat heater. The easy-to-work hydraulic operating controls (finger tip control levers or multifunction levers) allow to operate the wheel loader conveniently and ergonomically. The operator's well-being is ensured over long and productive hours.

SIMPLE & CONVENIENT OPERATION

Compact monitoring system

Arranged directly in front of the driver, an anti-dazzle, illuminated display makes it possible under all lighting conditions to read all instruments and information clearly. The driver's seat and steering column are infinitely-adjustable, allowing an ergonomic and comfortable seating position for any driver. All switches are logically arranged, and are outstanding on account of their functionality and ease of familiarisation.



Easy and comfortable operation due to hydrostatic drive

The hydrostatic drive ensures maximum operating comfort. Speed and direction can be altered directly and without sudden jerks. The electronically controlled variable hydraulic motor enables full-auto shifting and eliminates gearshift and kick-down operations.



Variable shift control

With the variable shift control, independent of the position of the accelerator pedal, and without loss of driving force, the travelling speed can be adjusted infinitely. This "creep function" has distinct advantages when working with attachments like a rotary cutter or a sweeper or improved operability at confined sites and easier dozing operations.



Smooth ergonomic hydraulic control

The new pilot control levers are designed as finger tip control levers for precise and fatigue-free control of the loading process. The position of the wristrest can be adjusted for all operators preferred height. A forward/reverse switch is located next to the levers so that the travel direction can be selected by touch.



Multi-function lever (Option)

A multi-function lever with integrated forward/reverse switch is also available as optional equipment. The servo-assisted multi-function lever ensures the simplest and most comfortable operation of the equipment. Simultaneously, the driver can change between forward and reverse direction with the rocker switch. The multifunction lever is the right choice for earth moving jobs.



DIMENSIONS & PERFORMANCE FIGURES

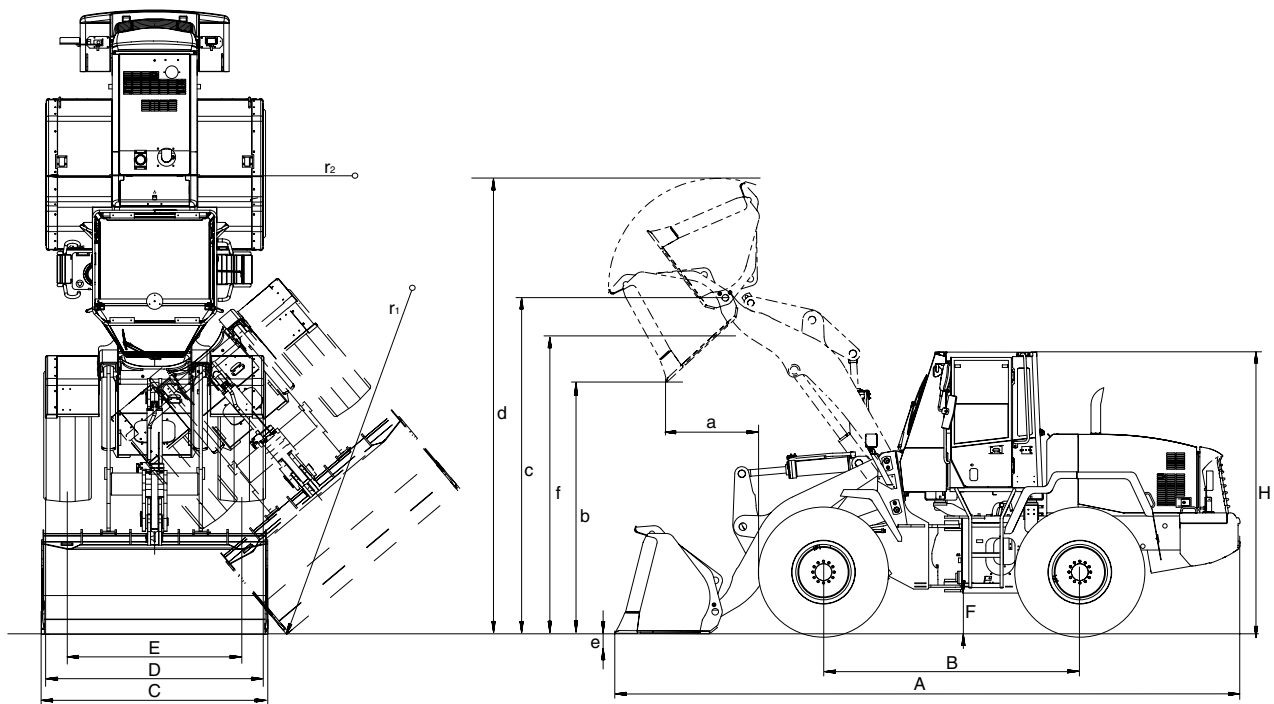

Measurements and working specifications

	WA250-5 (Z-bar kinematics)				WA250PT-5 (Parallel tool kinematics)			
	Earthmoving	Universal	Stock pile		Universal	Stock pile	Light mat.	High dump
Bucket type (buckets w/o teeth)	direct	direct	direct	QC	QC	QC	QC	QC
Bucket mount (direct/quick-coupler)	direct	direct	direct	QC	QC	QC	QC	QC
Bucket capacity (heaped, ISO 7546) m ³	2,1	2,1	2,4	2,4	2,0	2,4	4,0	4,0
Sales Code	W31	C01	C21	C44	C01	C21	W41	W30
Material density t/m ³	1,8	1,8	1,6	1,5	1,7	1,4	0,8	0,7
Bucket weight without teeth kg	1.040	910	1.040	1.000	910	1.040	1.260	1.900
Operating weight (without add. counterw.) kg	11.700	11.570	11.700	11.930	12.800	12.930	13.150	13.790
Static tipping load, straight kg	9.910	10.010	9.890	9.100	8.670	8.490	8.320	7.680
Static tipping load, 40° articulated kg	8.650	8.700	8.650	7.850	7.545	7.365	7.195	6.555
Break-out force hydraulic kN	128	125	121	105	121	109	93	65
Lifting capability hydr. at ground level kN	136	135	135	135	105	105	100	95
r ₂ Turning radius at corner of tires mm	5.240	5.240	5.240	5.240	5.240	5.240	5.240	5.240
r ₁ Turning radius at bucket edge mm	5.750	5.795	5.735	5.790	5.920	5.975	6.100	6.300
a Reach at 45° mm	1.020	1.020	1.050	1.195	1.085	1.120	1.285	1.545
b Dump height at 45° mm	2.905	2.905	2.895	2.725	2.885	2.885	2.630	4.280
c Hinge pin height mm	3.785	3.785	3.785	3.785	3.960	3.960	3.960	3.960
d Height top edge of bucket mm	5.120	5.100	5.120	5.430	5.400	5.420	5.600	5.800
e Digging depth mm	100	100	100	100	90	90	90	90
f Max. loading height at 45° mm	3.495	3.495	3.495	3.495	3.705	3.705	3.705	4.600
A Overall length, bucket grounded mm	6.925	6.925	6.925	6.925	7.275	7.325	7.575	7.925
B Wheelbase mm	2.900	2.900	2.900	2.900	2.900	2.900	2.900	2.900
C Bucket width mm	2.550	2.550	2.550	2.550	2.550	2.550	2.750	2.750
D Width over tires mm	2.470	2.470	2.470	2.470	2.470	2.470	2.470	2.470
E Track width mm	1.930	1.930	1.930	1.930	1.930	1.930	1.930	1.930
F Ground clearance mm	460	460	460	460	460	460	460	460
H Overall height mm	3.240	3.240	3.240	3.240	3.240	3.240	3.240	3.240

All measurements with tires 20.5 R25 L-3. Details of dumping heights and reach to cutting edge or bolt-on cutting edge. Details given are for buckets without teeth; if equipped with teeth: dump height -159 mm, dump reach +159 mm, overall length +225 mm.

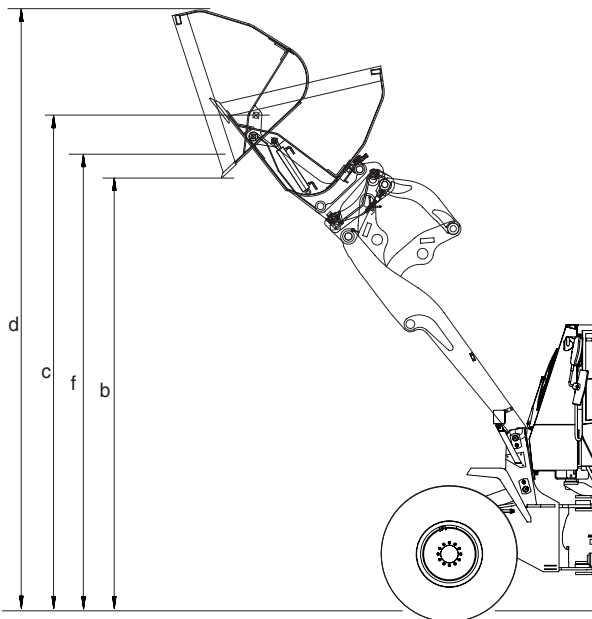
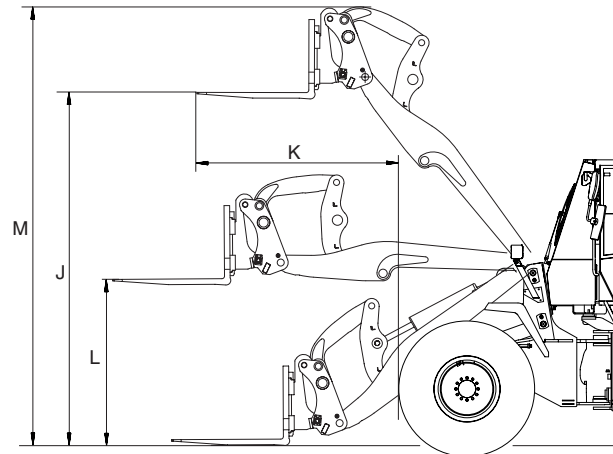

Illustration: 4.000 ltr super-light material high dump bucket



Performance figures with fork tines		
J	Max. stacking height	3.790 mm
K	Max. reach	3.006 mm
L	Height of forks at maximum reach	1.748 mm
M	Top edge, fork-tines	4.710 mm
Weight in working order with fork tines		12.540 kg
Max. tipping load, straight ISO 8313		7.200 kg
Max. tipping load, articulated		6.300 kg
Max. payload as per EN 474-3, 80%		5.040 kg
Max. payload as per EN 474-3, 60%		3.780 kg

All measurements as fitted with tires 20.5 R25 L-2.
Fork-carrier and tines in standard version.

Change in data caused by:			
		Add. counter-weight	Equipment with teeth
Weight	kg	+ 305	+ 100
Stat. tipping load, straight	kg	+ 725	- 60
Stat. tipping load, 40° angle	kg	+ 520	- 115
Overall length (A)	mm	-	+ 65

Typical material density - loose (in kg/m ³)	
Basalt	1960
Bauxite, Kaolin	1420
Earth, dry, ex store	1510
Earth, wet, excavated	1600
Gypsum, broken	1810
Gypsum, crushed	1600
Granite, broken	1660
Limestone, broken	1540
Limestone, crushed	1540
Gravel, unscreened	1930
Gravel, dry	1510
Gravel, dry, 6-50 mm	1690
Gravel, wet, 6-50 mm	2020
Sand, dry, loose	1420
Sand, damp	1690
Sand, wet	1840
Sand and clay, loose	1600
Sand and gravel, dry	1720
Sandstone	1510
Slate	1250
Slag, broken	1750
Stone, crushed	1600
Clay, natural	1660
Clay, dry	1480
Clay, wet	1660
Clay and gravel, dry	1420
Clay and gravel, wet	1540

DIMENSIONS & PERFORMANCE FIGURES

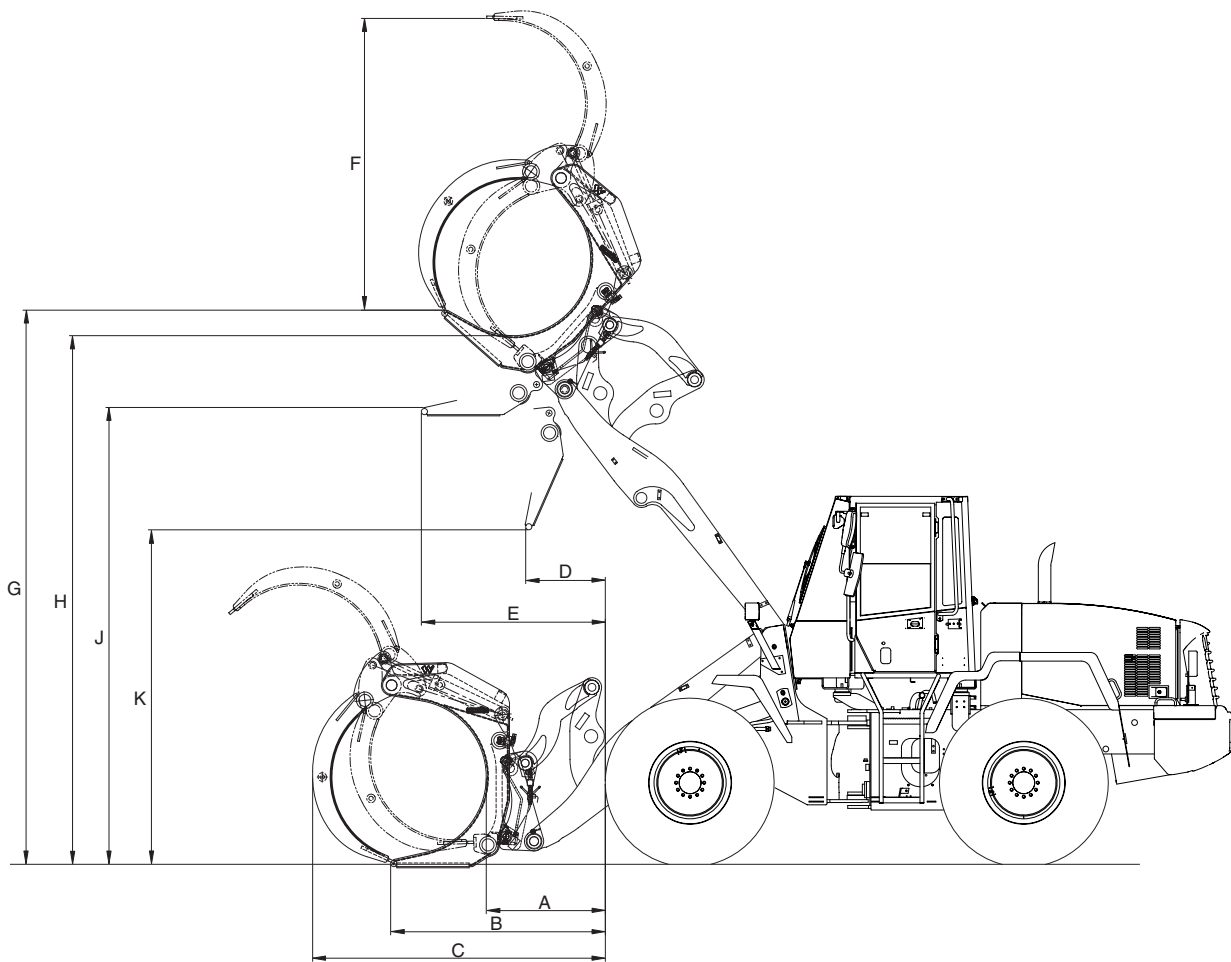

Performance figures with log grapple

Area	1,4 m ²
Max. payload	4.300 kg
Timber length	4,75 m
Grapple weight	1.000 kg
A	988 mm
B	1.781 mm
C	2.428 mm
D	660 mm
E	1.526 mm
F	2.420 mm
G	4.595 mm
H	4.384 mm
J	3.788 mm
K	2.773 mm

All measurements with tires 20.5 R25 L-2.

TECHNICAL DATA



ENGINE

Type	Komatsu SAA6 D102 E water-cooled, 4-stroke, turbocharged, with air-to-air intercooler
Rated power	101 kW/135 HP (SAE J1349) at engine speed 2.000 rpm
Torque/engine speed	max. 618 Nm/1.400 rpm
No. of cylinders	6
Bore/stroke	102/120 mm
Displacement	5,9 l
Injection system	Direct injection
Lubricating system	Gear pump, pressure feed lubrication filter
Filter	Main-flow filter
Electrical system	24 V
Battery	105 Ah
Alternator	60 A
Air-filter type	Dry-air filter with automatic dust emission and preliminary purification including a dust display



TRANSMISSION

Drive system	Electronically controlled hydrostatic transmission, switchable in all directions under full power Fixed ratio gearbox on the rear axle. Variable speed limiter
Hydrostatic pump	1 variable piston pump
Hydrostatic motor	2 variable piston motors
Speed ranges (forwards/backwards)	4/4
Max. travel speeds (forwards/backwards)	
1./2. speed range	13 km/h
3. speed range	18 km/h
4. speed range	38 km/h



CHASSIS AND TIRES

System	4-wheel drive
Front axle	HD axle, semi-floating, fixed type LSD/TPD-differential
Rear axle	HD axle, semi-floating, center-pin support LSD/TPD-differential, 30° swing angle
Reduction gear	Spiral bevel gear
Differential	Straight bevel gear pair
Final drive	Planetary gear in an oil bath
Tires	20.5 R25 (standard)



SERVICE REFILL CAPACITIES

Cooling system	17,5 l
Fuel tank	181 l
Motor oil	19,5 l
Hydraulic system	67 l
Axle (both front and rear axle)	18 l
Transfer	6,9 l



BRAKES

Operating brakes	Completely hydraulic dual-circuit system, running in oil bath multi-disc brakes on all wheels, service-free
Parking brake	Operated mechanically, running in oil bath multi-disc brake, service-free
Emergency brake	Independent service brake system



HYDRAULIC SYSTEM

Hydraulic pump	Gear pump
Working pressure	210 bar
Circulating capacity of the hydraulic pump	96 + 67 l/min
No. of boom/bucket cylinders	2/1
Type	Double-action
Bore diameter × stroke	
Boom cylinder	130 × 717 mm
Bucket cylinder WA250-5	150 × 491 mm
Bucket cylinder WA250PT-5	180 × 600 mm
Hydraulic control lever	Servo-controlled, 2-levers
Hydraulic cycle with rated load bucket filling	
Raise time	6,3 s
Lowering time (empty)	3,3 s
Dumping time	1,7 s



STEERING SYSTEM

System	Articulated frame steering
Type	Completely hydraulic power steering
Steering angle to either side	40°
Steering pump	Gear pump
Working pressure	190 bar
Pumping capacity	110 l/min
No. of steering cylinders	2
Type	Double-action
Bore diameter × stroke	70 × 453 mm
Smallest turn (outer edge of the tire 20.5 R25)	5.240 mm



CABIN

Two-door cabin in conformity with ISO 3471 with ROPS (roll over protective structure) in conformity with SAE J1040c and FOPS (falling object protective structure) in conformity with ISO 3449. The air-conditioned pressurised cabin is mounted upon hydrobearings and is noise dampened. Noise level inside cabin (according ISO 6395 dynamic noise levels): 72 dB(A)

STANDARD EQUIPMENT

Only for WA250-5:

- Universal bucket 2,1 m³ (SAE, heaped)
- Z-bar boom
- PPC fingertip control, 2-levers
- 2-spool main control valve

Only for WA250PT-5:

- Universal bucket 2,0 m³ (SAE, heaped)
- Parallel lift boom
- Integrated hydraulic 4-point quick-coupler
- Additional side counterweight
- Variable dump speed setting, 2-step return-to-dig
- PPC fingertip control, 3-levers
- 3-spool main control valve

For WA250-5 & WA250PT-5:

- Counterweight
- Automatic return-to-dig
- Automatic boom kick-out
- Swing-out radiator fan drive
- Power train guard
- 20.5 R25 L-2 tires
- Heavy-duty axles
- TPD-differential front and rear
- Electronically controlled HST with 2-motor system
- Constant speed control in 1st speed range
- Alternator 60 A
- Starter motor 4,5 kW/24 V
- Batteries 105 Ah/2x12 V
- Spacious double door driver's cab to DIN/ISO

- ROPS/FOPS frame to SAE
- All-round tinted glazing
- Front laminated glass
- Electronically controlled air conditioning
- Heated rear window
- Rear window wiper
- Air-suspended seat
- Sun visor
- Seat belt (EU standard)
- EMMS (Equipment Management Monitoring System) with self-diagnostic function and maintenance display
- Traction control system (TCS)
- Adjustable steering column
- Stereo-cassette radio
- 2 halogen main headlights

- 2 spotlights at front and rear
- Reversing light
- Horn
- Emergency steering system
- Vandalism protection
- Tool-set

General operating certification, in accordance with German Road Traffic Regulations. The WA250-5/PT-5 is equipped in accordance with the safety regulations of the machinery guidelines 89/392 EWG ff and EN474, and corresponds in its exhaust gas emission values with the regulations of the EC 2000/14, VIII and EC 97/68 Stage II regulations.

OPTIONAL EQUIPMENT

Only for WA250-5:

- 3-spool main control valve
- Quick-coupler
- Add. counterweight 305 kg

For WA250-5 & WA250PT-5:

- Electronically controlled, load stabilizer (ECSS)
- Automatic central lubrication
- Limited-slip differential (LSD) front and rear
- 550/65 R25 tires
- 600/65 R25 tires
- Universal bucket 2,2 m³
- Earthmoving bucket 2,1 m³
- Earthmoving bucket 2,2 m³

- Stock pile bucket 2,4 m³
- Stock pile bucket 2,5 m
- Light materials bucket 4,0 m³
- High-Dump bucket 4,0 m³
- All buckets direct or quick-coupler mount
- Various tooth systems, BOC, segments, (Komatsu/KVX™) and other optional bucket accessories are available on request
- Log grapples
- Special buckets
- PPC control, 1-lever (Multi-function lever)
- Batteries 143 Ah/2x12 V

- Back-up alarm
- Beacon light
- Additional lights front and rear
- Front screen protective grid
- Cab air protective ventilation
- Exhaust gas particles filter
- Turbo II pre-filter
- Electronic anti-theft lock
- 20 km/h version
- Battery main switch
- Fire extinguisher
- Biodegradable oil for hydraulic system
- Special custom colour
- Wastehandler specification
- Anti-Corrosion specification

Further equipment on request

KOMATSU

www.komatsueurope.com