

WA420-3 *active plus* All highlights at a glance.

AMS: The AMS Application Mode Selection enables the operator to adjust the machine optimally to the requirements of each operation. Highest performance or lowest fuel consumption are therefore guaranteed.

Spacious ROPS/FOPS cab on hydrobearings with air-conditioning. Low interior noise level $L_{pA} = 73$ dB(A) (95/27/EEC).

Travelling functions and control data are monitor-displayed in the operator's field of vision and easy to check by the service staff using the memory function.

High power and low consumption: The 8.3 l turbocharged, intercooled low-emission diesel engine 162 kW/220 hp (ISO 9249).

APS: The Automatic Power Speed system matches the hydraulic operating data to the actual conditions. "Fast" for short loading cycles. "Power" when moving right into the material.

The ALS-Electronic: Absorbs vibrations and protects operator and machine according to load and speed (optional extra).

Sturdy KOMATSU axles - fully floating and of heavy design - for all operations. They insure a long machine life.

Fully-automatic transmission with "kick-down" and "gear-hold".

Fully capsulated multiple wet-disc parking brake, integrated into the transmission and maintenance free.

Locking differentials for better traction. With a locking value of 45 % as option or TPD differentials as standard.

Perfectly designed rear for good visibility and easy stockpiling.

KOMATSU wheel loaders: The best of both worlds.

Wheel loaders of the WA 3-series were the first products developed and built in Hanover for Europe. The new *active plus*-series is the logical further development of this successful series. Apart from

the construction of wheel loaders the plant in Hanover is also specialized in the design and fabrication of waste compactors, axles and transmission.

KOMATSU

KOMATSU HANOMAG
Aktiengesellschaft



Hanomagstr. 9
30449 Hannover
Germany

Tel.: ++49 511/45 09-0
Fax: ++49 511/45 09-185
<http://www.komatsuhanomag.de>
<http://www.komatsu.com>

VESS074702

KOMATSU



WA420-3

active **plus**

Compact power with high manoeuvrability.
Top performance and user-friendly in everyday work.

Engine output: 162 kW/220 hp (ISO 9249)
Bucket sizes: 3.6 – 4.2 m³
Operating weight: 20.1 t

Loads better comfort • Loads better for the environment • Loads better performance

The philosophy behind the design of the WA420-3: Ruggedness, power and manoeuvrability.

Fast in rubble recycling.

The best of both worlds.

It can safely be said that the WA420-3 sets new standards in the field of 3.5 - 4.0 m³ wheel loaders. The WA420-3 wheel loader combines the know-how of two different worlds, because design engineers from Japan and Germany have both brought their long experience and expertise to the design and production of these high-capacity machines. This particularly applies for the active plus line now introduced to the market. These special wheel loaders put high value on operating comfort and environmental awareness.

The WA420-3 active plus is one example of the high quality and the outstanding performance of the WA series.

Durability - a design requirement.

During the development of the WA420-3 active plus, particular emphasis was placed on the requirement for rugged components, particularly in areas of specific stress.

This helps to explain the tough axle layout and the rigid chassis, which have been designed for long machine life.

All the other features and dimensions of the machine, from engine to bucket-linkage, have been designed to meet this fundamental philosophy.





WA420-3 in load & carry operation.



The operator feels at home straight away.

Not just because he can reach his workplace easily through wide opening doors, but because he is surrounded by ideal ergonomics, as the extremely low noise level means he can work "in peace" and because the air conditioning fitted as standard provides him with a really pleasant working environment and driving comfort comparable to that of a passenger car.

Jack-of-all-trades with staying power.

Whatever the job you assign to the WA420-3 - it will do rehandling work as professionally as rubble recycling. To achieve this new AMS Application Mode helps the operator to choose the optimum mode for the job.

A positive answer to the question of economy.

A lot of value for money is what you are bound to get with the WA420-3: When using the novel AMS-system the operating costs can be reduced further. The result is an even greater efficiency per working hour - for instance in rehandling work where it fills a semitrailer easily in 4 loading cycles. Thanks to top quality, a sensible overall concept and, by no means least, the guaranteed service friendliness. An investment in a WA420-3, therefore, pays for itself in the shortest of time.

What a workplace: Climb in and feel at home.



Ergonomically designed main monitor.

Climb in and feel at home.

The design of the workplace is decisive for an employee's commitment. Everybody who feels good, works better. Whether earning his pay at a desk or on a machine. That is why everything has been done on the WA420-3 to create an ideal workplace.

The force of peace.

The low noise level inside the cab results from specially designed features: the operator's cab is connected to the chassis by hydrobearings, the transmission "floats" on rubber buffers. The transmission of structure-borne noise from the drive units is prevented or reduced to a minimum.

Everything in view, everything in reach.

The first thing you notice inside the operator's cab is the expanded legroom and the ergonomically arranged control elements. The steering column including the monitor panel can easily be adjusted to perfectly suit the driver's position. The sitting position on the standard air suspension seat is high, providing complete all round vision and a direct view of the front wheels through the tinted windows.

The precision two-lever hydraulic control (optional single-lever or multi-function lever operation) is servo controlled and, coupled with the jerk-free automatic transmission, enables speeds to be adjusted to individual working conditions, with ease.

The "kick-down" function makes work even easier. It is topped off by the "gear-hold" switch which allows the operator to use the braking effect of the engine when driving downhill.

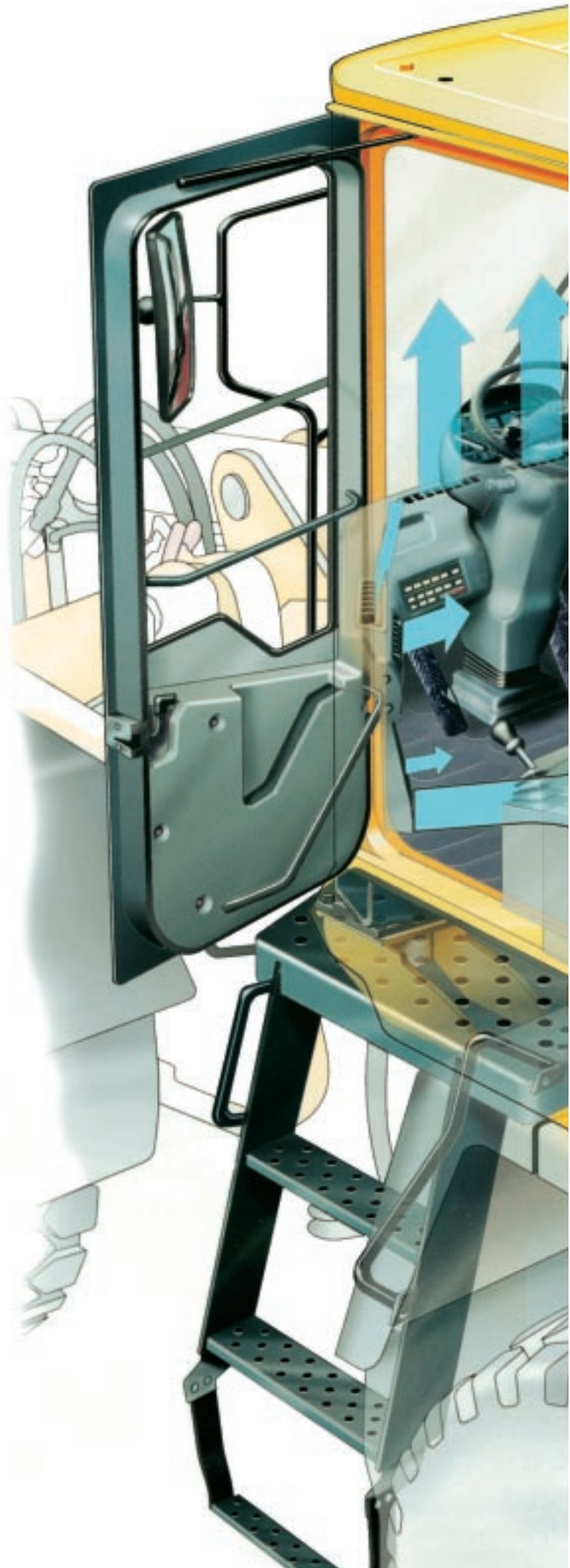

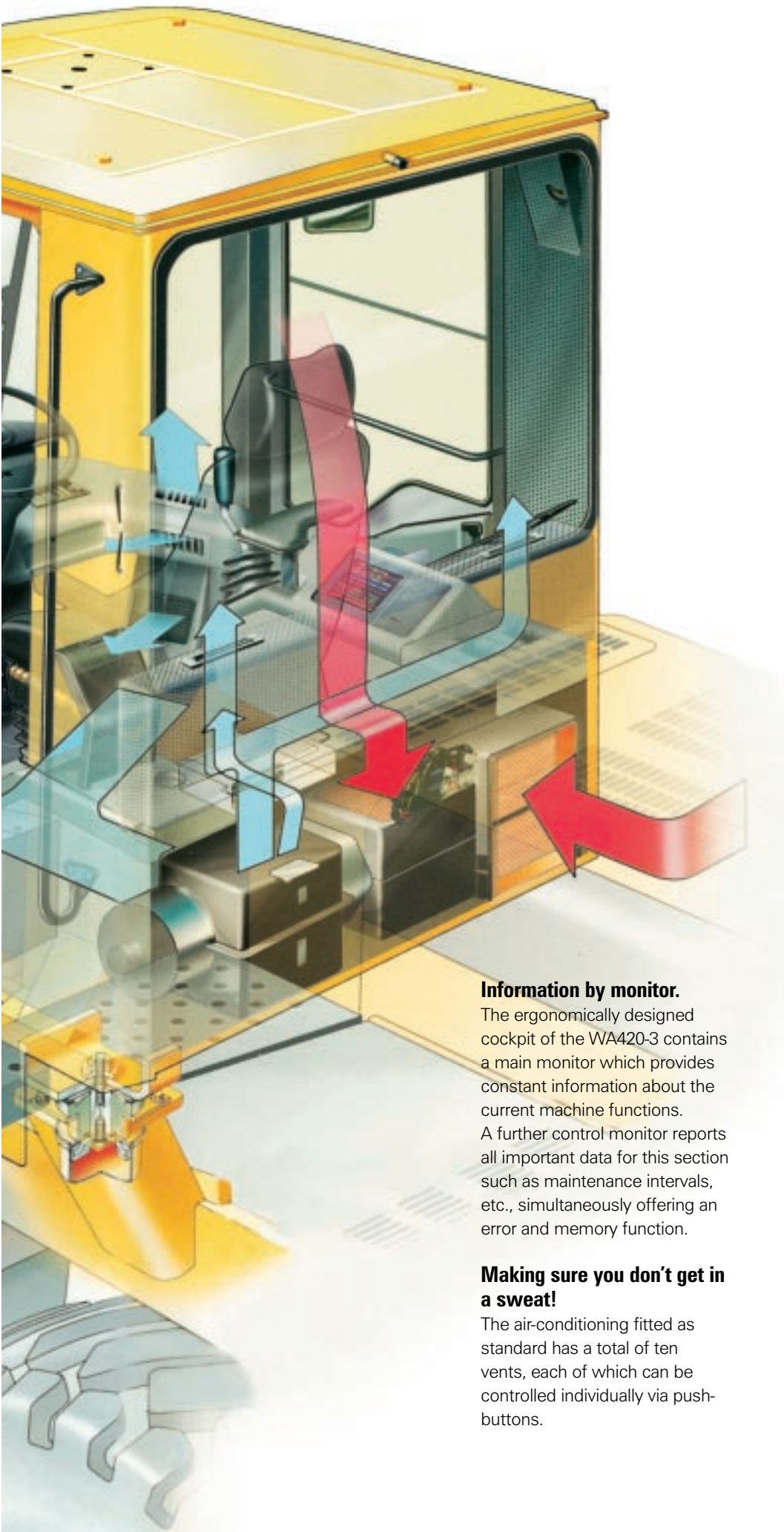

Information by monitor.

The ergonomically designed cockpit of the WA420-3 contains a main monitor which provides constant information about the current machine functions. A further control monitor reports all important data for this section such as maintenance intervals, etc., simultaneously offering an error and memory function.

Making sure you don't get in a sweat!

The air-conditioning fitted as standard has a total of ten vents, each of which can be controlled individually via push-buttons.

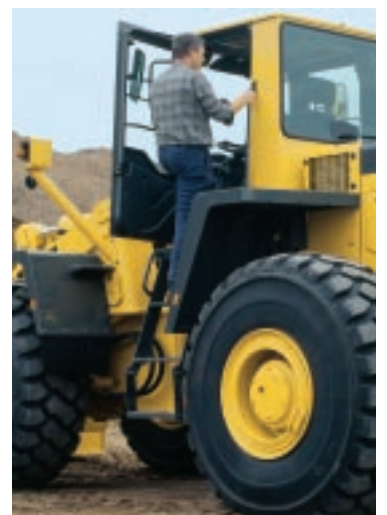
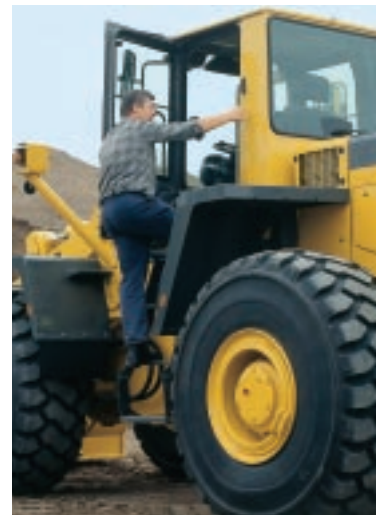
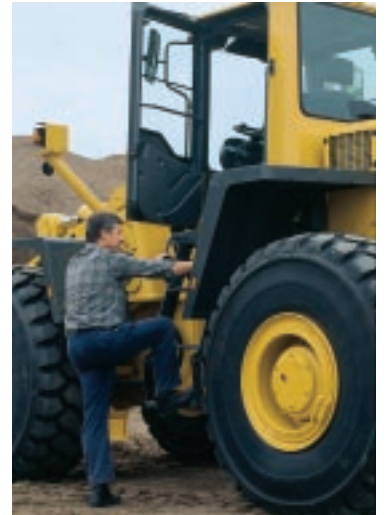

Ergonomic access and a spacious cab further increase the operating comfort.

In each situation the right mode: On button pressure or automatically.

ALS ELECTRONIC

The Electronic Automatic Load Stabiliser System, protecting man and machine (optional extra).

Strictly reduced vibrations and jolts thanks to the ALS Electronic.

This outstanding shock reduction system works with two pressure stages (full or empty bucket) and is automatically activated at 5 km/hour.

Vibrations and jolts are reduced to a minimum. The result: reduced stress for man and machine

for instance under fast load & carry conditions over uneven ground. The electronic system senses input parameters covering travelling speed, gearing and the pressure in the bucket cylinder. The system adjusts automatically to constantly-changing operating conditions.

APIS SYSTEM

*The Automatic Power-Speed-System – speed or power?
The system decides.*

Extremely flexible.

The APS system is a hydraulic system which automatically adjusts to individual operating conditions. The system decides for itself when power is called for, or when speed would be more advantageous.

Actually it's quite simple why things suddenly go fast.

"Fast" hydraulics are required when you need to carry out short loading cycles in extremely restricted spaces. Main and alternating pumps together supply a high flow-rate at a maximum of 328 l/min at an oil pressure of 160 bar. The result: fast bucket lift and fast tipping.

Actually it's quite simple why power is suddenly concentrated.

During heavy tear-out and lifting work, the resistance acting on the hydraulic system rises. At this point, the alternating pump switches off automatically and the main pump alone will supply a reduced oil flow-rate of 217 l/min.

The system pressure rises to a maximum of 210 bar, and the entire power will be transferred to the bucket, or is made available to the transmission for powerful traction into the material.

Power reversal via Z-kinematics.

The Z-kinematics are characterised by a high tear-out force and bucket discharge. This is achieved by power reversal of the tilt ram.

When filling the bucket (tear-out) the oil pressure acts on the large piston surface, whereas it acts on the smaller differential surface of the piston during the dumping process. This empties the bucket extremely rapidly and largely prevents the adhesion of cohesive materials. Due to the double-sealed bearing joints, extremely long maintenance intervals are also achieved.

Rigid and torsion-free frame.

The frame is very rigid due to large dimensions between joints. This grants maximum strength to the overall construction and reduces the load on the articulated joint. The 40° turning angle gives the machine its extremely high manoeuvrability.

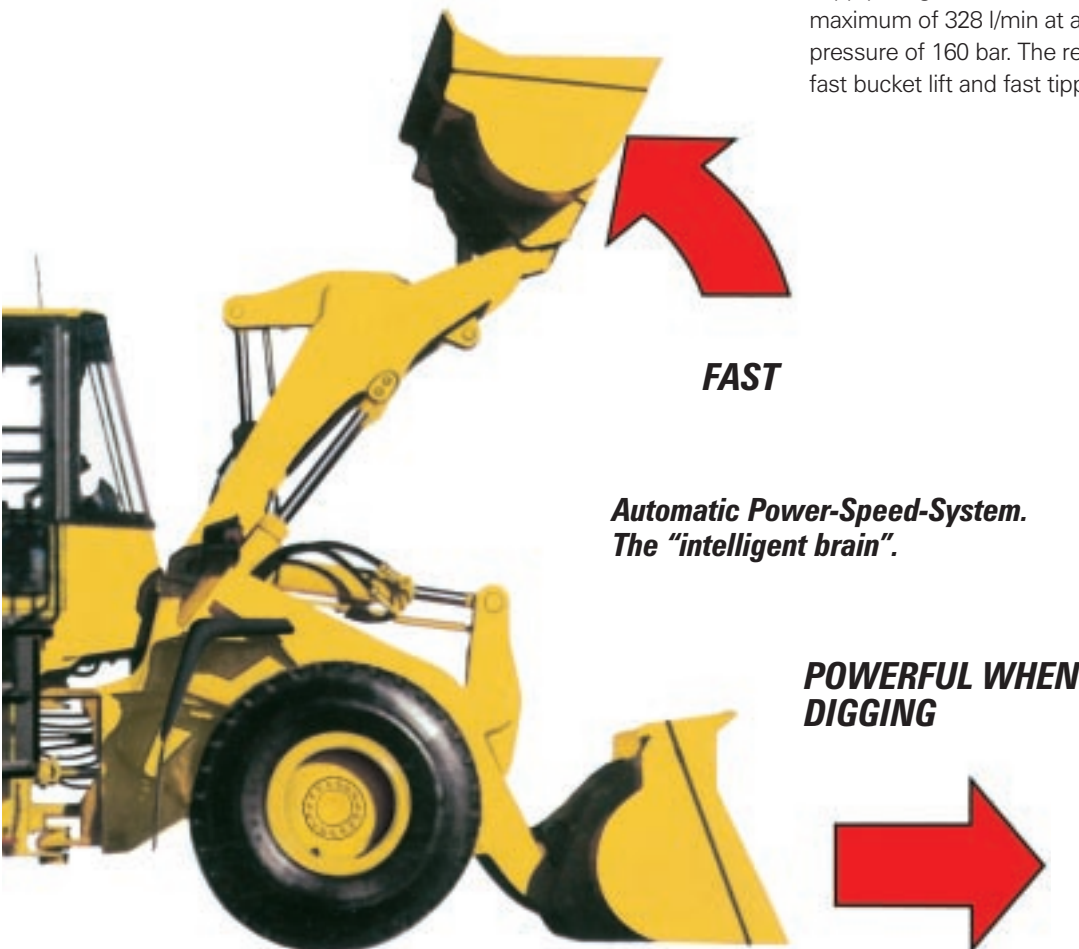

**Automatic Power-Speed-System.
The "intelligent brain".**

**POWERFUL WHEN
DIGGING**



Efficiency – by the press of a button.

The operator adapts the wheel loader to each operation by button pressure. Ergonomically integrated into the instrument panel all important main components such as engine, transmission and hydraulic system are adjusted optimally to the wishes of the operator and the requirements of the job.

Selected modes

High:

Powerful for fast V-shape loading, for example for the loading of trucks. The APS 2-stage hydraulic system and a maximum engine rpm guarantee fast hydraulic cycle times. The "late" gear shift from the 2nd to the 3rd gear ensures the maximum tractive power and fast loading and dumping sequences. This mode should be selected when maximum performance is required .

Standard:

Smooth for road travel as well as slow V-shape loading and "load & carry". The "early" gear shift reduces engine rpm and fuel consumption. The permanent disconnection of the switch pump reduces hydraulic loss and therefore fuel consumption. The reduced engine speed at "load & carry" means reduced engine wear and a reduction of noise level. The maximized engine rpm guarantees fast travel speed on the road.

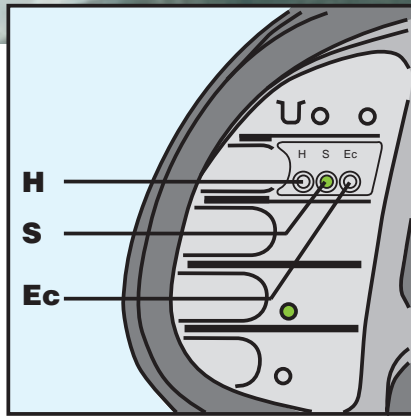

Powerful, smooth or efficient – make your own choice.

Economy:

Efficient for Load & Carry and light duty job applications. This selected mode provides lowest operating costs and highest efficiency. Further to the adaptations carried out to the transmission and hydraulic systems the engi-

ne management is controlled. The reduction of the engine rpm effected with this selected mode leads to a further reduction of fuel consumption when accelerating.



To steer with the little finger.

A further innovative feature is the optional joy stick. Integrated into the arm of the operator's seat it provides the operator easy and low effort steering during reversing in a loading operation. "To steer with the little finger" saves a thousand turns of the steering wheel every day and keeps the operator fit.

All-round toughness: A powerful engine, a robust chassis and ruggedly-built axles.

Maximum performance calls for stamina.

A wheel loader is subject to extreme conditions because it has to cope with a wide variety of jobs: Driving from site to site, reversing, lifting, breaking out, pushing earth loads, etc. The machine is under incredible stress, from the axle right down to the smallest bolt. That is why the WA420-3 - like all the other wheel loaders in the WA active plus series - has a "sturdy

constitution". And constructive features that make these machines exceedingly robust.

Under pressure it feels at its best.

The double-sealed bucket bolts and the KOMATSU heavy-duty axles easily handle any load. The state of the art KOMATSU SAA6D114E low-emission engine with intercooler keeps everything moving under power. With an impressive result.

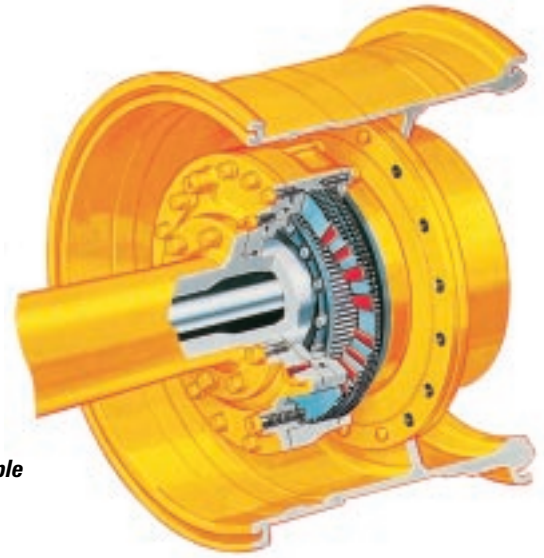

Outboard planetary final drives and multiple wet disc brakes.



162 kW/220 hp - an exceedingly powerful, state of the art low-emission engine.

The turbocharged 6-cylinder engine with charge-air intercooler from KOMATSU gives the WA420-3 exceptional smoothness, flexibility and high torque. This gives you the power reserves you need – whether in mining, in sand or in recycling. Very moderate fuel consumption and excellent combustion are significant factors for econo-

my and resolute environmental awareness. And easily accessible service points for easy maintenance go without saying.

Multiple wet disc parking brake.

Designed as multiple wet disc type, oil-immersed and integrated in the transmission case, the brake is completely enclosed thus preventing wear and making it completely maintenance free. Furthermore, the

multi-disc service brake is an oil-immersed type and protected against mud and dust. The brake system is fully hydraulic giving a further step towards a maintenance-free machine.

Central lubrication factory fitted.

The optional KOMATSU-central lubrication system in the particularly robust heavy-duty design provides clean maintenance and low down time even in the heaviest operations.

Making sure the wheels always grip.

Self-locking differentials front and rear with a locking value of 45 % are a guarantee for good traction at all times, even on soft ground, for heavy pushing work, or on slopes (option). TPD torque proportioning differentials guarantee the wheel loader's powerful feed and low tire slip making it a real low-cost solution.

Into gear smoothly.

There are four gears each for forward and reverse drive. The gear ratios are practice-related and provide jerk-free gear-change and reversing even under full load. The automatic transmission is particularly advantageous and takes the burden off the operator, as does the "kick-down", for changing down to 1st gear in a flash in order to

Exhaust limit values in g/kWh in accordance with ISO 8178

| | | | |
|-----------------|------|------|------|
| 9,2 | 0,7 | 1,3 | 5,0 |
| 8,46 | 0,44 | 0,90 | 0,84 |
| NO _x | PM | HC | CO |

■ **EC limit values**

■ **Actual values of the WA420-3 active plus**

move into the material at full power. Furthermore the new AMS-system provides optimized gear shifts and increased efficiency.

In harmony with the environment - not only due to the low exhaust values.

We hardly think it worth mentioning that our low-emission engines are well within the future European and international exhaust directives. The high-pressure injection plus a modified turbocharger give the wheel loader low-noise force and staying power. The hydraulic system operates optionally with bio-oil and is thus in perfect harmony with the environment, for instance in water-protected areas. Taken altogether - an investment which pays for itself in the shortest of time.



Easily accessible service points for cab filter and the engine and transmission make service work simple and clean.



Dimensions and operating data.

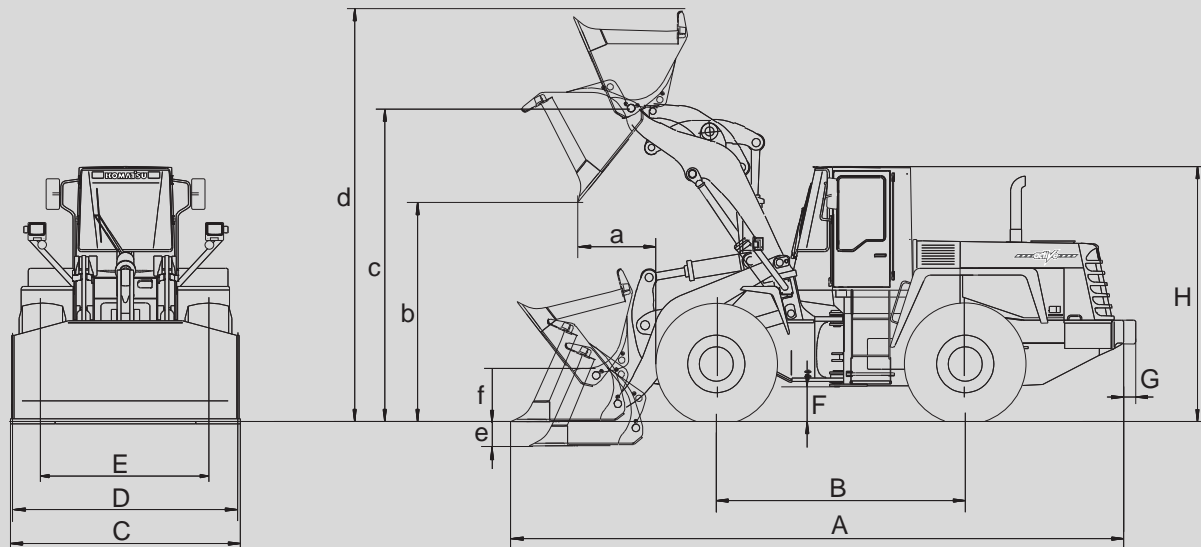

| Buckets (capacities according to ISO 7546) | m ³ | 3.6 | 4.0 |
|--|------------------|--------|--------|
| Specific density | t/m ³ | 1.8 | 1.6 |
| Bucket weight without teeth | kg | 1,845 | 1,975 |
| Static tipping load (straight) | kg | 15,600 | 15,120 |
| Static tipping load (at a 40° angle) | kg | 13,660 | 13,240 |
| Breakout force, hydraulic | kN | 182.7 | 171.7 |
| Hydraulic lifting capacity, on ground | kN | 211 | 250 |
| Operating weight** | kg | 20,120 | 20,250 |
| a Reach at 45° | mm | 1,016 | 1,072 |
| b Dumping height at 45° | mm | 3,035 | 2,980 |
| c Lift height, hinge pin | mm | 4,186 | 4,186 |
| d Height to upper edge of bucket | mm | 5,720 | 5,720 |
| e Digging depth | mm | 35 | 35 |
| f Bucket height when travelling | mm | 470 | 470 |
| A Overall length | mm | 8,020 | 8,100 |
| B Wheelbase | mm | 3,300 | 3,300 |
| C Bucket width | mm | 3,000 | 3,000 |
| D Width across tyres | mm | 2,880 | 2,880 |
| E Track | mm | 2,200 | 2,200 |
| F Ground clearance | mm | 465 | 465 |
| H Overall height | mm | 3,450 | 3,450 |

Special buckets:
 3.6 m³ HD bucket (recycling)
 5.8 m³ light-material bucket

The standard 3.6/4.0 m³ buckets shown in the table can also be supplied with bolt on cutting edges to increase capacities to 3.7/4.2 m³.

Data will be modified according to:

| | Additional counter-weight | Tire filling 26.5 R 25 |
|--------------------|---------------------------|------------------------|
| Weight | + 325 kg | + 1560 kg |
| Tip load: | | |
| 0° | + 875 kg | + 2530 kg |
| 40° | + 730 kg | + 2225 kg |
| Overall length (G) | + 175 mm | - |

L_{pA} = 73 dB(A)*
 L_{wA} = 108 dB(A)*

* according to directive 95/27/EC (new dynamic measurement).

** machine without additional counterweight.

These values refer to a machine fitted with 26.5 R 25 XHA L-3 tires.

When using 23.5 R 25 tires, the vertical dimensions will be reduced by 50 mm.

When using 705/70 R 25 tires, the vertical dimensions will be reduced by 70 mm.

| Bucket type | Capacities in m ³ | |
|-------------------|------------------------------|---|
| V-shape bucket | 3.3 | |
| Bucket | 3.6 | |
| Bulk mat. bucket | 4.0 | |
| Light-mat. bucket | 5.8 | |
| Density | in (t/m ³) | 0,9 1,0 1,1 1,2 1,3 1,4 1,5 1,6 1,7 1,8 1,9 2,0 |

The actual volume will usually exceed the ISO/SAE classification. The table shows optimum bucket data, depending on the material involved.

| Material | Bucket-contents % | Density t/m ³ |
|----------|-------------------|--------------------------|
| Earth | 100-115 | 1,5-1,6 |
| Clay | 110-120 | 1,5-1,7 |
| Sand | 100-110 | 1,4-1,8 |
| Gravel | 85-110 | 1,5-2,0 |
| Rock | 75-100 | 1,6-2,0 |

Not economical Recommended Full utilization

Technical data at a glance.



Engine

| | |
|------------------------------|--|
| Make | KOMATSU low-emission engine |
| Model | SAA 6D114 E-1 |
| Type | Turbocharged, intercooled diesel engine |
| Power output at engine speed | 162 kW/220 hp (ISO 9249) 2,200 rpm |
| Max. torque/speed | 900 Nm at 1300 rpm |
| No. of cylinders | 6 |
| Bore/stroke | 114/135 mm |
| Displacement | 8270 cm ³ |
| Compression ratio | 15,5 : 1 |
| Combustion system | direct injection |
| Cooling system | dual-circuit, thermostatically controlled liquid cooling |
| Electrical system | 24 volt |
| Batteries | 2 x 12 volt, 143 amp/h |
| Alternator | 50 amp/h |
| Air filter | HD dry-air filter |



Transmission

| | |
|------------------|---|
| Make | KOMATSU |
| Type | Fully-automatic 4-speed full powershift transmission with "kick-down" and "gear-hold" |
| Conversion ratio | 3.27:1 |



Steering

| | |
|------------------------------|--------------------------------------|
| Type | Hydrostatic |
| System | Articulated joint |
| Articulated joint | Needs no readjustment |
| Steering angle | 40° each side, hydraulically limited |
| Steering pump | |
| Operating pressure | 210 bar |
| Delivery | 111 l/min |
| Minimum turning radius | |
| Outside edge wheel | 6,054 mm |
| Outside edge standard bucket | 6,600 mm |
| Emergency steering | Via additional pump |



Filling capacities

| | |
|--|--------|
| Fuel | 340 l |
| Engine oil | 22.4 l |
| Cooling System | 50 l |
| Converter transmission/ powershift transmission | 60 l |
| Front axle | 60 l |
| Rear axle | 60 l |
| Operating hydraulics/brake system | 210 l |



Hydraulic system

| | |
|--|---|
| System | 2-stage, 3-pump system with main and 2 switch pumps |
| Operating pressure | |
| stage 1 | 160 bar |
| stage 2 | 210 bar |
| Operating flow | |
| stage 1 | 328 l |
| stage 2 | 217 l |
| Loading times | |
| Lift (full load) | 6.7 sec |
| Dump | 1.5 sec |
| Lower | 3.6 sec |
| Automatic boom kick-out, automatic return-to-dig | |



Axles

| | |
|-------------------|---|
| System | All-wheel drive, planetary reduction in the wheel hobs |
| Front axle | Planetary axle with TPD torque proportioning differential |
| Rear axle | Planetary axle with TPD torque proportioning differential, oscillating |
| Oscillating angle | 13° each side |
| Tires | 705/70 R 25 XLD70 L3, Michelin 26.5 R25 XHA L3, Michelin 26.5 R25 SPT 7LD, L3, Dunlop 26.5-25 PG 6S, 20PR, L3, Dunlop 26.5 R25 XLDD 1A, L4, Michelin 26.5 R25 XLDD 2A, L5, Michelin 26.5 R25 RL-2+, L2/3, Goodyear The listed 26.5 R 25 tire profiles are also available in size 23.5 R 25 |



Travel speeds

| | |
|---------|---|
| Forward | 1st gear 0 - 6.7 km/h 2nd gear 0 - 12.3 km/h 3rd gear 0 - 22.0 km/h 4th gear 0 - 38.5 km/h |
| Reverse | 1st gear 0 - 6.7 km/h 2nd gear 0 - 12.3 km/h 3rd gear 0 - 22.0 km/h 4th gear 0 - 38.5 km/h |



Brakes

| | |
|------------------|---|
| Operating brakes | Hydraulic pump accumulator brake system, wedge-type multi-disc brakes in wheel hubs (all-wheel brake) |
| Hand brake | Wedge-type multi-disc brake in transmission, spring-loaded, opening hydraulically |



Standard Equipment

Low-emission engine • two-door, noise-insulated high comfort cab (equipped with ROPS/FOPS) • air conditioning • air suspension operator's seat • openable door windows • stereo cassette radio • 2 halogen main lights • halogen work lights, front and rear • vandalism protection • AMS Application Mode Selection (H, S, Ec selected mode) • automatic transmission with additional kick-down and gear-hold • two-lever hydraulic operation • TPD differentials in front and rear axle • emergency steering • electronic checking system (EDIMOS II) • automatic power-speed hydraulic system (APS system) • automatic return-to-dig • automatic boom kick-out • 705/70 R 25 (radial) tires • all loading kinematics and bearing points sealed • integrated noise insulation • noise values: L_{WA} 108 dB(A), L_{pA} = 73 dB(A).

The WA420-3 is equipped in accordance with the professional safety regulations and fulfils the low-emission directives of ISO 8178 and the EC directive 95/27/EC.



Optional Equipment

23.5 R25 / 26.5 R25 tires • high-lift attachment • fold-down radiator grille • limited-slip differential, front and rear • StVZO German road safety compliance • electronically controlled load stabiliser (ALS-Electronic) • 3-spool valve • single-lever hydraulic operation • weighing facility • backup alarm • additional counterweight (325 kg) • additional counter weight II (460 kg) • central lubrication • special colour • rock and special buckets • special tires (e.g. rock, recycling, sand, clay, etc.) • tire chains • protective grille for windscreen • catalyst • speed limitation • TURBO II air-pre-cleaner • multi-function lever for transmission and hydraulic control • travel lock • for operation in quarry • hydraulic quick coupler • equipment for the wood industry (log grapple, light material- and high tip bucket) • additional working lights • roof railing • 3rd and/or 4th spool valves for additional hydraulic functions • heated operator's seat.