

KOMATSU®

WA80-5

NET HORSEPOWER
45 kW 60 HP @ 2.350 rpm

OPERATING WEIGHT
5.640 kg

BUCKET CAPACITY
0,9 - 1,25 m³

WA
80

WHEEL LOADER



WA80-5

WALK-AROUND

With its ground-breaking design, the WA80-5 revolutionises this class of compact wheel loaders: a long wheelbase, rear-axle oscillation, longitudinally installed engine, tiltable cab and everything built into a super-compact design – all the ingredients that deliver the benefits that really count for every compact wheel loader application.

Superior versatility

- Parallel movement during fork application with Easy Fork cinematic
- Tall dumping heights and long reaches
- High payloads in pallet fork application
- Market-compatible hydraulic quick coupler (standard)
- Optimum dimensions for working in confined spaces
- LSD axles (standard)
- 100% differential lock (optional)
- 30 km/h version standard
(20 km/h version optional)

Operator comfort

- Large cab space
- Ergonomic interior design
- PPC multifunction lever
- Huge glass area for greater comfort and visibility
- Large storage areas
- Easy entry cab
- Long wheelbase for superior travelling comfort
- Electronic Controlled Suspension System (ECSS) (optional)
- Air conditioning (optional)



Unrivalled productivity

- Bucket shape designed for superior penetration and filling capability
- Highest tipping loads and lifting capacities

NET HORSEPOWER
45 kW 60 HP

OPERATING WEIGHT
5.640 kg

BUCKET CAPACITY
0,9 - 1,25 m³

Excellent visibility

- Delta boom
- Elevated operator cab
- Sloped engine bonnet
- Narrow tail
- Heated rear window



Superb serviceability

- Tilttable cab
- Longitudinally installed engine
- Wide opening engine bonnet
- Easy-access radiator
- Maintenance-free fully hydraulic, wet disc service brakes

THE ADVANTAGES IN DETAIL



Productivity

One of the key factors that influences a wheel loader's performance is its bucket. Best penetration performance and optimum filling capability characterise the design of Komatsu buckets. Better filling capability also demands greater machine stability. Accordingly, the payload of the WA80-5 wheel loader, with its standard bucket, is class-leading 1.850 kg. In addition, the longitudinally installed engine helps to provide a well balanced weight distribution. During forklift applications, the minimum requirement for a compact wheel-loader is to be able to lift a pallet filled with bricks. With its forklift payload of 2.200 kg, and with the superb visibility of the fork, moving of these pallets is true child's play.



Versatility

Earthmoving and landscaping companies will especially welcome the rear axle-oscillation, which allows for excellent scooping, and generally provides the best stability. In addition, the 30 km/h top speed allows for fast relocation of the machine without the need of a transport truck. Industrial customers will also benefit from these features with reduced operator's fatigue, less tyre wear on concrete surfaces and faster production cycles. Furthermore, the WA80-5's elevated seat position ensures best visibility, thus enhancing safety.

Comfort

Safe and convenient daily travel is essential for a compact wheel loader whilst changing applications and job sites.

Komatsu wheel loaders offer first class riding comfort, thanks to their very long wheelbases. This makes small obstacles barely noticeable when travelling over them. And the rear axle oscillation provides suspension-like operator comfort. Operators will also appreciate the large cabin, which offers enough space for literally all of their belongings: A large closed storage box with enough room for a pair of boots, raincoat, hard hat and tools, plus a smaller closed storage box for smaller items such as mobile phones, cigarettes and lighter - and enough open space to store documents and other small belongings.



Ease-of-operation

Operators of compact wheel loaders are often challenged by a variety of applications and machines. Therefore, easy operation of each machine is a must. And this is where the WA80-5 excels: Parallel movement during pallet-fork applications, superb visibility of attachments and tyres, easy-to-reach switches and PPC multifunction lever. In addition, the WA80-5 features a standard supplied hydraulic quick-coupler that allows the change of equipment in the shortest time and with the least effort. Of course, attachments for the Dash-5 series are interchangeable with the Dash-3 loaders and other common makes.

Serviceability

Customers with large numbers of compact wheel loaders especially prefer to do their own servicing. This ensures the best availability of their equipment. And they want the servicing to be done as quickly as possible so that the equipment and the mechanics are available for other jobs. With the WA80-5, servicing is done in shortest time. Simply tilt up the cabin, and literally all components are easily accessible for servicing within a few moments. No dismantling of engine bonnets, no removing of the operator's cabin. Daily maintenance is even simpler. The longitudinally installed engine allows access to all sides of the engine block. All filters, fillers and gauges are easy to reach, and the radiator is free-standing for best cleaning access.



Safety

Working in confined areas and in today's challenging working situations, operators have to be continuously aware of their surroundings. The WA80-5, with its narrow, short overhang tail and its super-large windows, has been designed to give best all-around visibility. In construction and utility works, getting on and off compact wheel loaders is frequent. Easy, safe access to and from the cab is therefore very important for continuous workflow and a safe working environment. This is provided by the WA80-5's low entry step and by its super-wide-opening entry door.



DIMENSIONS AND PERFORMANCE FIGURES

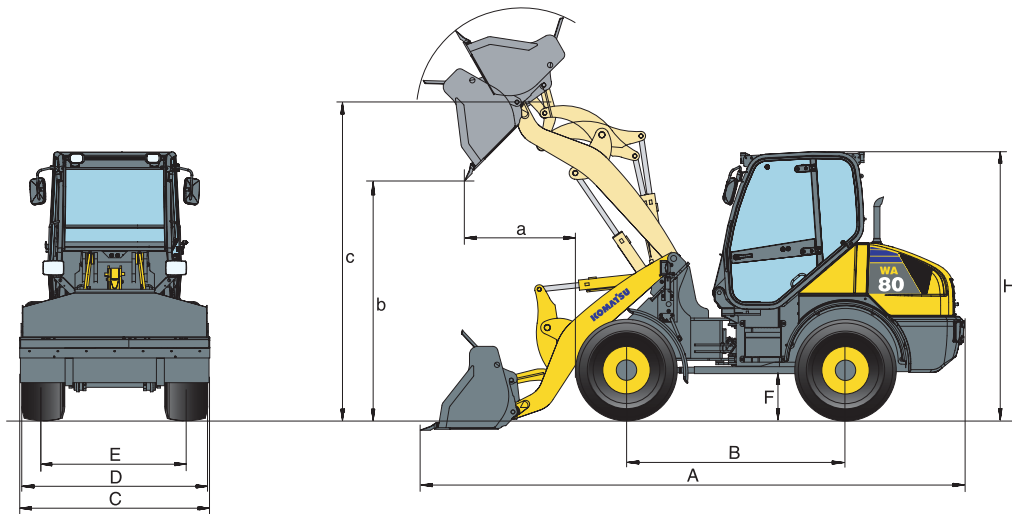

Measurements and working specifications						
Bucket type		Universal		Light materials		4-in-1
		w. teeth	w/o teeth	w/o teeth	w/o teeth	w/o teeth
Bucket capacity (heaped, ISO 7546)	m ³	0,90	0,90	1,00	1,25	0,80
Sales code	3926	C61	C11	C13	C14	C16
Material density	t/m ³	1,80	1,80	1,70	1,35	1,80
Bucket weight without teeth	kg	330	305	310	345	615
Static tipping load, straight	kg	4.325	4.350	4.170	4.120	3.790
Static tipping load, 40° articulated	kg	3.690	3.715	3.560	3.510	3.190
Break-out force hydraulic	N	4.620	4.620	4.270	3.790	4.290
Lifting capability hydr. at ground level	N	4.100	4.100	4.090	4.100	4.130
Operating weight	kg	5.640	5.615	5.620	5.655	5.925
Turning radius at corner of tyres	mm	3.825	3.825	3.825	3.825	3.825
Turning radius at bucket edge	mm	4.300	4.300	4.320	4.350	4.360
a Reach at 45°	mm	995	900	965	1.035	985
b Dump height at 45°	mm	2.425	2.520	2.400	2.330	2.425
c Hinge pin height	mm	3.210	3.210	3.210	3.210	3.210
d Height top edge of bucket	mm	4.150	4.150	4.080	4.260	4.100
e Digging depth	mm	90	90	130	130	100
f Max. loading height at 45°	mm	2.940	2.940	2.900	2.900	2.925
A Overall length, bucket grounded	mm	5.480	5.350	5.510	5.610	5.620
B Wheelbase	mm	2.200	2.200	2.200	2.200	2.200
C Bucket width	mm	1.915	1.915	1.870	1.870	1.900
D Width over tyres	mm	1.875	1.875	1.875	1.875	1.875
E Track width	mm	1.470	1.470	1.470	1.470	1.470
F Ground clearance	mm	300	300	300	300	300
H Overall height	mm	2.665	2.665	2.665	2.665	2.665

Performance figures with fork tines			
Sales code			C24
Fork tine length	mm		1.200
A Max. reach at ground level	mm		890
B Max. reach	mm		1.380
C Max. reach at max. stacking height	mm		680
a Max. height fork-carrier	mm		3.660
b Hinge pin height	mm		3.210
c Max. stacking height	mm		3.080
d Height of forks at maximum reach	mm		1.490
Max. tipping load, straight	kg		3.285
Max. tipping load, articulated	kg		2.835
Max. payload as per EN 474-3, 80%	kg		2.200
Max. payload as per EN 474-3, 60%	kg		1.700
Weight in working order with fork tines	kg		5.520

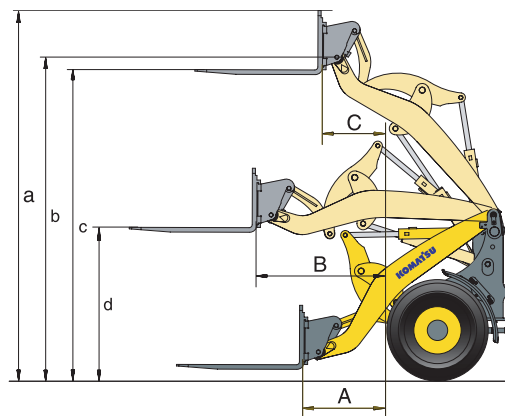

All measurements with tyres 405/70 R18

SPECIFICATIONS



ENGINE

Smooth running, emissionised KOMATSU diesel engine. Water-cooled for best heat balance and low noise emissions. Longitudinal mounted for best weight distribution and optimum service access from all sides.

TypeKomatsu 4D95-LE3
 Rated power 45 kW/60 HP (SAE J1349)
 at engine speed2.350 rpm
 Torque/engine speed max. 214 Nm/1.600 rpm
 No. of cylinders 4
 Bore x stroke 95 x 115 mm
 Displacement 3,3 ltr
 Injection system Direct injection
 Electrical system 12 V
 Battery 92 Ah
 Alternator 60 A
 Air filter type Dry air filter with pre-filter and safety cartridge



TRANSMISSION

Drive systemHydrostatic transmission,
 switchable in all directions under full power
 Hydrostatic pump 1 variable piston pump
 Hydrostatic motor 1 variable piston motor
 Speed ranges (forwards/backwards) 2/2
 Travel speeds (forwards/backwards) 20 km/h version
 1. speed range 0 - 4,5 km/h
 2. speed range 0 - 20 km/h
 Travel speeds (forwards/backwards) 30 km/h version
 1. speed range 0 - 8,5 km/h
 2. speed range 0 - 30 km/h



CHASSIS AND TYRES

Type Low build rear axle oscillation for optimum stability
 and for best performance in earthmoving applications
 System 4-wheel drive
 Axles Planetary rigid axles with automatic
 limited slip differentials in both axles
 100% locking differentials as option
 Oscillation Rear axle oscillation for optimum stability,
 oscillation angle 10°
 Tyres 405/70 R18 (standard)



SERVICE REFILL CAPACITIES

Cooling system 9,1 ltr
 Fuel tank 84 ltr
 Engine oil 7,5 ltr
 Hydraulic oil tank 30 ltr
 Front axle 8,6 ltr
 Rear axle 8,6 ltr



BRAKES

Operating brakesCombined inch brake pedal actuates
 maintenance free wet-disc type brakes in the front axle.
 Self-braking via the hydrostatic drive
 Parking brake Dry disc



HYDRAULIC SYSTEM

SystemOpen hydraulic system
 Working pressure 220 bar
 Circulating capacity of the hydraulic pump 57 ltr/min
 No. of boom/bucket cylinders 2/1
 Type Double-action
 Bore diameter x stroke
 Boom cylinder 70 x 658 mm
 Bucket cylinder 90 x 450 mm
 Hydraulic control lever Multifunction lever
 Kinematic Z-Kinematic with highest breakout force.
 Parallel movement when using dedicated fork tines.
 Hydraulic cycle with rated load bucket filling
 Raise time 4,9 s
 Lowering time (empty) 2,8 s
 Dumping time 0,9 s



STEERING SYSTEM

System Articulated frame steering
 Type Hydrostatic
 Steering angle to either side 42°
 Steering pump Gear pump
 Working pressure 185 bar
 No. of steering cylinders 1
 Type Double-action
 Bore diameter x stroke 70 x 363 mm
 Smallest turn (outer edge of the tyre 405/70 R18) 3.825 mm



CABIN

Cabin in conformity with ISO 3471 with ROPS (roll over protective structure) in conformity with SAE J1040c and FOPS (falling object protective structure) in conformity with ISO 3449. The pressurised cabin is mounted upon hydrobearings and is noise dampened.
 Tilttable for best servicing access.

WHEEL LOADER

STANDARD EQUIPMENT

- Universal bucket 0,9 m³ (SAE, heaped)
- Z-bar boom (Parallel movement when using dedicated fork tines)
- Hydraulic quick-coupler
- 3-spool main control valve
- Counterweight
- Tilttable cabin
- Emergency steering system
- Alternator 60 A
- Starter motor 2,2 kW/12 V
- Battery 92 Ah/12 V
- PPC multifunction lever
- Power train guard
- Tyres 405/70R18

- Heavy-duty axles
- LSD-differential front and rear
- Maintenance-free service brakes
- Combined brake/inching pedal
- Spacious driver's cab with heating
- ROPS/FOPS frame according to SAE
- All-round tinted glazing
- Front laminated glass
- Heated rear window
- Rear window wiper
- Suspended seat
- Sun visor
- Seat belt (EU standard)

- Adjustable steering column
- 2 halogen main headlights
- Reversing light, integrated into the rear spot-light
- Large storage box at left hand side
- Adjustable wrist rest with integrated small storage box
- Instrument panel with gauges for speed, hydraulic oil temperature, fuel level
- Vandalism protection
- Tool-set
- Horn

The WA80-5 is equipped in accordance with the safety regulations of the machinery guidelines 89/392 EWG ff and EN474, and corresponds in its exhaust gas emission values with the regulations of the EC 2000/14, VIII and EC 97/68 Stage II regulations.

OPTIONAL EQUIPMENT

- Electronically controlled load stabilizer (ECSS)
- 100% manual locking differentials front and rear
- 20 km/h version
- Tyres 335/80 R20
- Tyres 365/80 R20
- Tyres 375/75 R20
- Tyres 405/70 R20
- Tyres 12.5-20
- Tyres 14.5-20
- Tyres 16/70-20
- 4-in-1 bucket 0,8 m³
- Light materials bucket 1,0 m³
- Light materials bucket 1,25 m³

- High dump bucket 1,1 m³
- Mulch grapple bucket 0,7 m³
- Side dump bucket 0,7 m³
- Fork carrier and tines
- Sweeper
- All buckets and attachments quick-coupler mount
- Hydraulic quick connectors (according to ISO 16028)
- Creeping function
- Immobilizer
- Immobilizer with master key
- Adjustable high comfort seat
- Air conditioning
- Stereo-cassette radio

- Back-up alarm
- Beacon light
- Additional lights front and rear
- Battery main switch
- Biodegradable oil for hydraulic system
- Fire extinguisher
- Licence plate lights
- Special custom colour

Further work equipment, accessories and special application arrangements on request

KOMATSU®

Komatsu Europe International NV

Mechelsesteenweg 586
B-1800 VILVOORDE (BELGIUM)
Tel. +32-2-255 24 11
Fax +32-2-252 19 81
www.komatsueurope.com

VESS000100 10/2005

Materials and specifications are subject to change without notice.

KOMATSU® is a trademark of Komatsu Ltd. Japan.