

KOMATSU

Utility

WB
97S-2



WB97S-2

WB97S-2

4 - WHEEL STEERING
BACKHOE LOADER

NET POWER
SAE J1349
73 kW - 97,8 HP

OPERATING WEIGHT
From 8.190 kg
to 9.030 kg

POWERED BY COMFORT

Comfort and operational simplicity. With a KOMATSU backhoe loader work is simple and above all pleasant.

Engine

The WB97S-2 uses a KOMATSU 97.8 HP turbocharged engine. The high displacement of this engine (4.4 l) guarantees extensive reserve torque and power and above all exceptional reliability. Furthermore, the modern technology used ensures minimum gas emissions, in compliance with the strict European STAGE 2 standards, thanks to the high efficiency and low noise combustion system.



Transmission

The WB97S-2 is fitted with "Full Power Shift" transmission, which guarantees permanent traction of the wheels, even during gear changes, and makes it possible to reach a maximum speed of 40 km/h. The semiautomatic, electronically-controlled gear selection system is operated using a knob, in a manner that is simple and intuitive for the operator. The **EGM (Electronic Gear Management)** system, which is available as an option, allows automatic or semiautomatic gear selection. The EGM also manages other important functions, such as:

- system self-diagnosis
- automatic engagement and disengagement of the 4-wheel drive
- activation of the anti-theft alarm system with customised code

Axles and Brakes

The sturdiness and efficiency of the transmission are further enhanced by the adoption of "Heavy-Duty" axles and limited-slip differential on both axles. Maximum operating safety is also guaranteed by the excellent braking system, featuring multiple-disk service brakes in oil bath with independent circuits activated by two separate pedals.



Four-wheel steering

The hydrostatic power steering with “Load Sensing” device and priority valve ensures a smooth and precise drive. The new KOMATSU system offers 3 different steering modes:

- two-wheel steering
- four-wheel steering (all wheel steering) for agile and fast operations
- crab steering for access to confined areas

The WB97S-2 is fitted with a new electronic display. This shows the following information, in 6 languages:

- alignment of the front and rear axle
- speed in km/h or Mph
- partial service hours indicator
- maintenance and emergency indicators
- programmed maintenance operations (every 500, 1.000 and 2.000 operating hours)
- tyre pressure indicator.



Hydraulic System

The KOMATSU backhoe loaders are equipped with the consolidated “Syncro System” hydraulic system. The heart of the system is the variable flow-rate pump that feeds the exclusive **CLSS (Closed Load Sensing System)**. This system ensures that only the power strictly necessary is delivered and used, as well as guaranteeing high operating efficiency in all conditions. Furthermore, the innovative **LIFD distributor (Load Independent Flow Divider)** allows the speed of each movement to be completely independent from that of the others, and the proportionality remains unchanged even when the resisting load changes. Basically, the hydraulic system ensures, as well as excellent performance, shorter working cycles and thus greater productivity.

The two operating modes, “Power” and “Economy”, ensure maximum power when required, or alternatively reduced power to save fuel when performing more general operations or finishing-off.



Cab

No backhoe loader can rival its visibility: maximum window area, front windscreen extension at the top, less bulky and better positioned uprights, a steeply inclined front hood free of all obstacles. The ergonomic layout of the controls in the cab allows the operator to comfortably manage all the machine's functions.

Ample space ensures optimum comfort inside the cab; the new air-conditioning system, available upon request, provides the ideal temperature in all weather conditions, thus guaranteeing maximum comfort for the operator. The brand-new **PPC** proportional servo controls (optional) are fitted on two fully adjustable columns. They offer the maximum as to comfort and ergonomics, as well as more precision in the movements than traditional controls.

Backhoe

Thanks to the sturdiness of the structure and the effectiveness of the hydraulic system, the backhoe provides significant tearout and digging force.

The functional geometry ensures excellent dumping height and digging depth, while at the same time guaranteeing minimum encumbrance on the road and perfect visibility of the work area. Performance and sturdiness combined with extreme versatility, enhanced by the availability of the telescopic arm or the device to dig beyond the wheel outline, as well as the combination of the two. To complete all these versatile characteristics, there is also the possibility to fit the machine with a wide range of buckets and special equipment.



KOMATSU



Loader

The divergent geometry of the loader arm ensures excellent dumping height and above all perfect visibility.

Furthermore, the specific kinematic motion guarantees excellent parallelism.

These characteristics, together with the innovative hydraulic system, ensure exceptional tearout and lifting force values.

A special "Speed Up" button instantly increases the speed of the loader.

The possibility to use numerous attachments, such as the 4x1 bucket and the forks, highlights the versatility of this front loader.

The optional **LSS** device (**L**oad **S**tabiliser **S**ystem) provides exceptional stability and comfort during material loading and transfer operations and when driving on the road.



Maintenance

Checks and routine maintenance on the KOMATSU backhoe loaders take just a few minutes, and are extremely simple to perform, without requiring any special equipment.

The extended greasing intervals reduce unning costs and service times, and increase the returns on the investment.



SPECIFICATIONS



ENGINE

The engine has been developed in compliance with the strictest European standards (97/68/CE - STAGE 2) on the reduction of exhaust emissions.

Model Komatsu S4D106-2SFA
 Type.....vertical, 4-cycle water-cooled diesel engine
 Displacement4412 cm³
 Cyl. bore x stroke106 x 125 mm
 N° of cylinders.....4
 Compression ratio.....17,5:1
 Combustion.....direct injection (DI)
 Aspiration.....turbocharged
 Gross power74,5 kW
 Maximum rated power:
 (SAE J 1349)73 kW / 97,8 HP / 2.200 rpm
 (80/1269/EC)72 kW / 96,5 HP / 2.200 rpm
 Max torque378 Nm - 1.600 rpm
 Cooling systemradiator
 Air filterdry filter with safety element
 Starting systemelectric motor with pre-heating air system for cold climate



OPERATING WEIGHT

Standard machine operating weight.....8.190 kg
 Total machine weight.....9.030 kg
 operating weight increase
 4x1 bucket250 kg
 offset boom150 kg
 telescopic arm260 kg
 pallet forks200 kg



HYDRAULIC SYSTEM

SyncroSystem hydraulics allows the operator very precise and simultaneous movements. This system is energy efficient and incorporates two different working modes: Power and Economy. The advanced hydraulic system includes also the function “*Speed Up*” to increase the working speed of the front loader.

System.....*SyncroSystem*
 Type.....Close Load Sensing System CLSS
 Pumps type.....Variable displacement axial pistons
 Pumps control system.....Load Sensing
 Main Valve (backhoe).....LIFD (*Load Independent Flow Divider*)
 modular type
 Max delivery.....165 l/min
 Working pressure.....200 bar



ELECTRIC SYSTEM

The electric system is easily accessible and protected: connections are sealed and waterproof, and comply with the strictest international safety rules.

Voltage.....12 V
 Battery155 Ah
 Alternator80 A
 Starter3 kW



FRAME

The frame is modular and has been developed for computer based welding processes; every main element is bolted directly to the frame to improve maintenance and to reduce down time.



STEERING

The front and rear steering wheels are controlled by a “Load-Sensing” hydrostatic power steering system with a priority valve and by an electronic device for the selection of the 3 steering modes.

Steering radius, with 4 steering wheels and inner wheel not braked:
 loader outer angle4.390 mm
 outer wheel4.150 mm

The values are valid either with 24” and with 28” tyres.



TRANSMISSION

Electronically-controlled, four-wheel drive, “*Full Power Shift*” transmission. EGM (*Electronic Gear Management*) gear controls for changing driving direction and gears, in automatic or semi-automatic mode (using two buttons), at full power without disengaging the drive. Other functions incorporated: system self-diagnosis, automatic connection/disconnection of the four-wheel drive, and activation of the anti-theft alarm using a PIN code.

Travelling speed: GEAR	FORWARD	REVERSE
1 st	6,5	6,5
2 nd	12	12
3 rd	23	23
4 th	40	-



AXLES

“Heavy-duty” axles with planetary reduction gears in the wheel hubs. Front axle total oscillation angle 16°. Limited slip differential on both axles.

Max front strength (Dynamic)8.000 daN
 Max rear strength (Dynamic)10.000 daN



BRAKES

Oil immersed disc brakes are actuated by individual braking on each rear wheel with 2 separate pedals. Total integral braking (4th gear) on the 4 wheels is activated by operating the two pedals at the same time.

Disc diameter270 mm
 Total friction area.....2.310 cm²
 The parking or safety brake acts on the service brakes through a hand operated lever.



TYRES

Standard:16.9 x 24 - 12 PR
 Option:16.9 x 28 - 12 PR
 16.9 x 28 radial tyres



CAB

ROPS (ISO 9249, SAEJ1040) and FOPS (ISO 3449, SAEJ 231) cab designed in order to offer the best visibility, ergonomics, low noise and comfort. Two doors, full opening rear windows with front and rear windscreen wipers. Internal lay out includes full adjustable seat, fresh filtered air intake ventilation and easy to read front and side dash board.

WB97S-2 BACKHOE LOADER



LOADER

The design of the front loader allows an excellent tensile strength distribution and the upkeep of movement parallelism when lifting and lowering the bucket. Furthermore, thanks to the linkage geometry the greasing points have been reduced.

Standard bucket width	2.420 mm
Standard bucket capacity (ISO 7546)	1,1 m ³
STD bucket weight	440 kg
Lifting capacity	
at maximum height:	3.820 daN (3.900 kg)
Lifting capacity	
at ground level (ISO 8313):	5.195 daN (5.300 kg)
Breakout force (ISO 8313)	6.383 daN (6.500 kg)
4x1 bucket width	2.440 mm
4x1 bucket capacity (ISO 7546)	1,03 m ³



REFILLS

Engine oil	8,6 ℓ
Cooling system	18 ℓ
Diesel tank	130 ℓ
Hydraulic oil tank	92 ℓ
Front axle oil	13 ℓ
Rear axle oil	12 ℓ
Gearbox oil	16 ℓ



BACKHOE

The main boom has a reinforced structure built with cast ends, allows 180° rotations, always maintaining high rotation torque. Vertical outriggers with adjustable wear device.

Bucket breakout force (ISO 6015)	5.780 daN (5.900 kg)
Arm breakout force (ISO 6015)	3.780 daN (3.850 kg)

DIMENSIONS

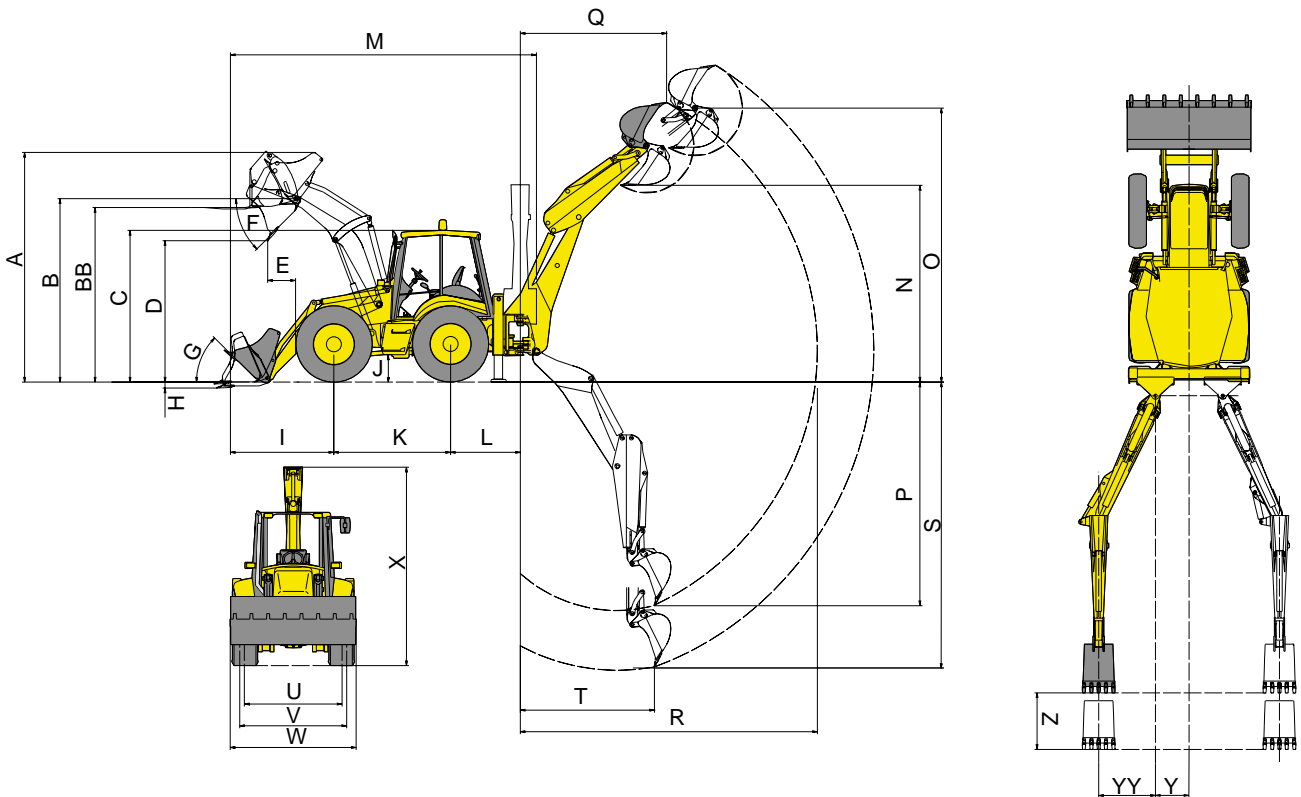

A. max height	4.220 mm	P. digging depth SAE	4.500 mm
B. pin height	3.440 mm	- with extended telescopic	5.650 mm
BB. forks loading max height	3.200 mm	Q. reach at max height	2.500 mm
C. cab height	2.810 mm	- with extended telescopic	3.500 mm
D. max dumping height	2.750 mm	- with extended off-set	2.510 mm
E. max dumping reach (45°)	750 mm	R. max reach from swing centre	5.550 mm
F. dumping angle	45°	- with extended telescopic	6.550 mm
G. rollback angle	45°	S. max digging depth	4.950 mm
H. digging depth	110 mm	- with telescopic	6.100 mm
I. bucket reach (in transport)	1.930 mm	T. digging reach	2.750 mm
J. ground clearance	470 mm	U. rear tread	1.950 mm
K. wheel base	2.175 mm	V. front tread	1.950 mm
L. backhoe swing centre distance	1.320 mm	W. overall width (with bucket)	2.420 mm
M. transport length	5.895 mm	X. transport hoe height	3.660 mm
N. dumping height SAE	3.700 mm	- with telescopic	3.700 mm
max dumping height	3.950 mm	- with off-set	3.760 mm
- with extended telescopic SAE	4.830 mm	Y. side shift	605 mm
- with extended telescopic max	5.050 mm	YY. side shift with off-set	1.080 mm
O. max digging height	5.510 mm	Z. telescopic stroke	1.150 mm
- with extended telescopic	6.510 mm		

- Values with 16.9 x 24 tyres

STANDARD EQUIPMENT

<ul style="list-style-type: none"> • Turbo STAGE 2 Komatsu engine • "Full Power Shift" with electronic control (EGM): <ul style="list-style-type: none"> - automatic or semi-automatic selection - direction and gear indicator - electronic anti-theft system with code • "Kick-down" function • 4 wheel drive • Limited slip differential on both axles • 4 wheel steering (3 modes) with electronic alignment • Front mudguards • Declutch switch • Foot pedal and hand control accelerator • Horn • Maintenance-free battery 155 Ah • 12V external electric plug • 12V power outlet in the cab • Antifreeze (-36°C) • Front and rear working lights 	<ul style="list-style-type: none"> • Road homologation • Lights for road travel • Rotating beacon • Internal and external mirrors • ROPS/FOPS cab with heater and fan • Tinted glass • Adjustable steering wheel • Adjustable seat with safety belt • Front and rear windshield wipers • Lockable internal storage compartment • Clothes hook and cup-holder • Fully opening bonnet • Air cleaner, dry type, radial seal with clogging indicator and safety internal filter • Fuel filter with water separator • "Load sensing", variable displacement axial pump • Multiple function digital display showing: <ul style="list-style-type: none"> - front and rear axle alignment - speedometer (km/h or mph) 	<ul style="list-style-type: none"> - type of oil for engine, transmission, brakes and hydraulic system - routine maintenance operations to be performed every 500, 1.000 and 2.000 with partial service hours - language selection (Italian, English, German, French, Spanish, Portuguese) - tyre pressure - maintenance and warning alarms • Indicators: transmission oil temperature, 4WD engagement, brake oil level, differential lock, fuel level indicator, hour meter, engine tank reservoir, preheating, engine speed, engine coolant temperature, engine oil pressure, air filter clogging • Front counterweight (300 kg)
LOADER <ul style="list-style-type: none"> • Speed-Up 	<ul style="list-style-type: none"> • Lifting cylinder safety lock 	<ul style="list-style-type: none"> • General purpose bucket with bolted teeth
BACKHOE <ul style="list-style-type: none"> • Electro-hydraulic backhoe shifting lock 	<ul style="list-style-type: none"> • Backhoe swing transport lock 	<ul style="list-style-type: none"> • Electro-hydraulic backhoe slide frame release lock

OPTIONAL EQUIPMENT

<ul style="list-style-type: none"> • PPC proportional servo controls • Air Conditioning • Additional front counterweight (170 kg) • De-Luxe seat with 3" retractable safety belt • Drive shaft guard (front) • Optional tyres • Bumper • Cold area arrangement (-22°C) 	<ul style="list-style-type: none"> • Cold area arrangement (-30°C) and engine pre-heater • TÜV + TBG version (20 km/h or 40 km/h) • Battery disconnection safety switch • Rubber pads for stabilisers • Hose burst valves: <ul style="list-style-type: none"> - loader arm - backhoe - stabilisers 	<ul style="list-style-type: none"> • Hydraulic biodegradable oil • Hydraulic hand hammer circuit • Air cyclone pre-filter • Fuel filling pump • Additional toolbox • Additional rear view mirror (right) • Radio • Backup alarm
LOADER <ul style="list-style-type: none"> • LSS (<i>Load Stabiliser System</i>) • Auxiliary hydraulic circuits: <ul style="list-style-type: none"> - auxiliary 3rd spool valve with floating function - auxiliary 3rd spool valve with floating function and "Return-To-Dig" - front auxiliary hydraulic circuit - additional front auxiliary hydraulic circuit (6-way valve) 	<ul style="list-style-type: none"> • Attachments: <ul style="list-style-type: none"> - bolt-on cutting edge - cutting edge on teeth - 4x1 bucket - flip-over forks on 4x1 bucket - hydraulic and mechanic quick hitch - forks (for quick hitch) - gen. purpose bucket (for quick hitch) 	<ul style="list-style-type: none"> - 4x1 bucket (for quick hitch) - angle-dozer blade (for quick hitch)
BACKHOE <ul style="list-style-type: none"> • Alternative control pattern • Auxiliary hydraulic circuits: <ul style="list-style-type: none"> - hammer aux. circuit - auger aux. circuit - 2-way aux. circuit for hydraulic attachments (including clamshell bucket with 	<ul style="list-style-type: none"> hydraulic swing) • Offset boom • Telescopic arm • Offset boom with telescopic arm • Attachments: <ul style="list-style-type: none"> - mechanical quick hitch (for std buckets) 	<ul style="list-style-type: none"> - range of buckets (300 mm ÷ 900 mm) - ditch cleaning bucket (1.400 mm) - ditch digging bucket (1.000 mm) - hydraulic hammer

KOMATSU

Komatsu Utility Europe

Head Office
via Atheste 4
35042 Este (Padova) - Italy
Tel. +39 0429 616111
Fax +39 0429 601000
www.equipmentcentral.com
utility@komatsu.it



COMPANY WITH
ENVIRONMENTAL MANAGEMENT
SYSTEM CERTIFIED BY DNV
ISO 14001